



Pump Division

***Durco[®]
Mark 3[™]
ANSI Chemical
Process Pumps***

***Mark 3 Standard
Sealmatic
Lo-Flo
Recessed Impeller
Unitized Self-Primer***



Pump Supplier To The World

Flowserve is the driving force in the global industrial pump marketplace. No other pump company in the world has the depth or breadth of expertise in the successful application of pre-engineered, engineered and special purpose pumps and systems.

Pumping Solutions

Flowserve is providing pumping solutions which permit customers to continuously improve productivity, profitability and pumping system reliability.

Market Focused Customer Support

Product and industry specialists develop effective proposals and solutions directed toward market and customer preferences. They offer technical advice and assistance throughout each stage of the product life cycle, beginning with the inquiry.



Dynamic Technologies

Flowserve is without peer in the development and application of pump technology, including:

- Hydraulic engineering
- Mechanical design
- Materials science
- Intelligent pumping
- Manufacturing technology

Broad Product Lines

Flowserve offers a wide range of complementary pump types, from pre-engineered process pumps, to highly engineered and special purpose pumps and systems. Pumps are built to recognized global standards and customer specifications.

Pump designs include:

- Single stage process
- Between bearing single stage
- Between bearing multistage
- Vertical
- Submersible motor
- Rotary
- Reciprocating
- Nuclear
- Specialty

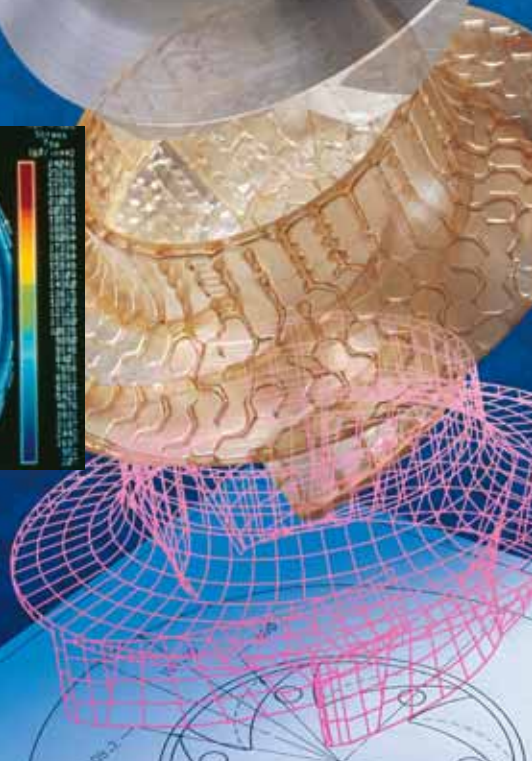
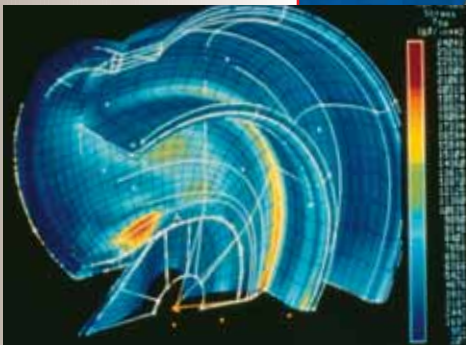

Mark 3 Family of ANSI Chemical Process Pumps

The Premier Name in ANSI Chemical Process Pumps

The Mark 3 family of ANSI chemical process pumps offers a wide range of configurations including mechanically sealed, dynamically sealed, low-flow, self-priming and recessed impeller pumps. The Mark 3 family, therefore, provides flexibility and breadth of pumping solutions in countless applications throughout the worldwide process industries.

Applications

- Acid transfer
- Brine
- Chemical processing
- Petrochemical processing
- Corrosive services
- Food and beverage processing
- Hydrocarbon processing
- Pharmaceuticals
- Polymers
- Pulp and paper
- Sea water
- Slurries
- Solvents
- Steel and primary metals
- Water and wastewater treatment

Complementary Pumps

- CPX ISO chemical process pump
- Mark 3 ANSI in-line chemical process pump
- Guardian magnetic drive chemical process pump
- PolyChem M-Series ANSI and ISO fluoropolymer lined magnetic drive pumps
- PolyChem S-Series ANSI and ISO fluoropolymer lined chemical process pumps
- GRP ANSI engineered polymer composite chemical process pump
- FRBH heavy-duty paper stock and process pump

Table of Contents

Mark 3 Standard Pump

.....4-5
Performance Curves6

Features and Enhancements

Parts
Interchangeability7
PROS+7
Power Ends8
Shaft and Bearings Design.....9
SealSentry10-11
Impellers12-13
Shaft Options.....14
Pump Parts.....15
Alloy Materials15
Baseplates16-19
Options.....20-21
Pump Power Monitor33

Mark 3 Lo-Flo Pump

.....22-23

Mark 3 Sealmatic Pump

.....24-25

Mark 3 Self-Priming Pump

.....26-27

Mark 3 Recessed Impeller Pump

.....28-29

Complementary Pumps

Mark 3 In-Line30
Non-Metallic Pumps31
Magnetic Drive Pumps32
CPX Family of ISO Pumps34

Engineered Services35

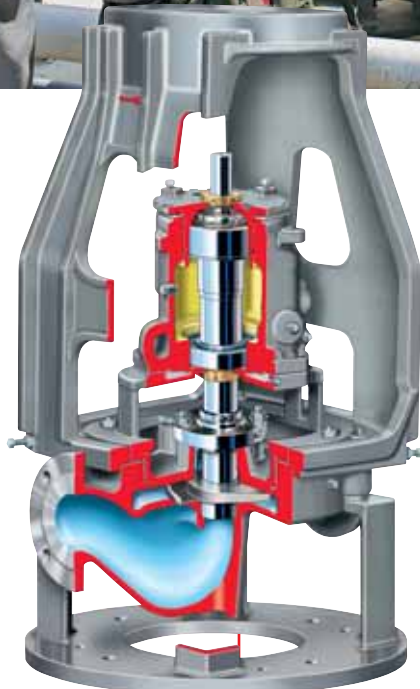

Mark 3 In-Line

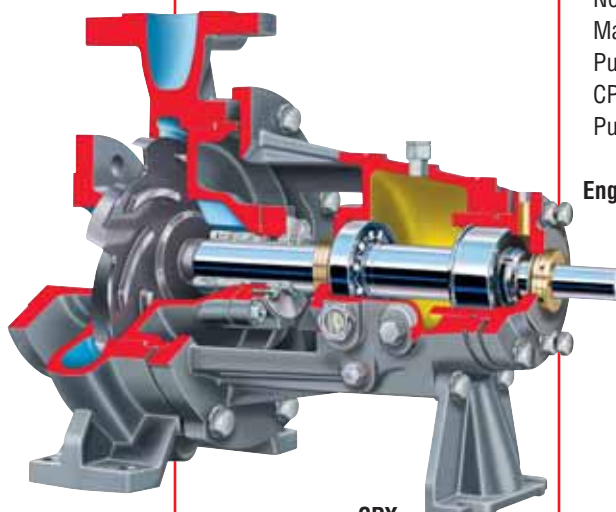

CPX

**Mark 3 Standard
ANSI Chemical
Process Pump**

**World Renowned for
Reliability and Performance**

The Flowserve Durco Mark 3 pump is recognized worldwide as the premier name in ANSI chemical process pumps. Conforming to ANSI B73.1 and incorporating advanced design features, the rugged Mark 3 standard pump provides unmatched performance and reliability.

Operating Parameters

- Flows to 1680 m³/h (7400 gpm)
- Heads to 215 m (700 ft)
- Pressures to 27 bar (400 psi)
- Temperatures from -73°C (-100°F) to 370°C (700°F)

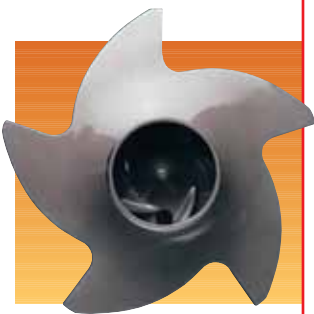
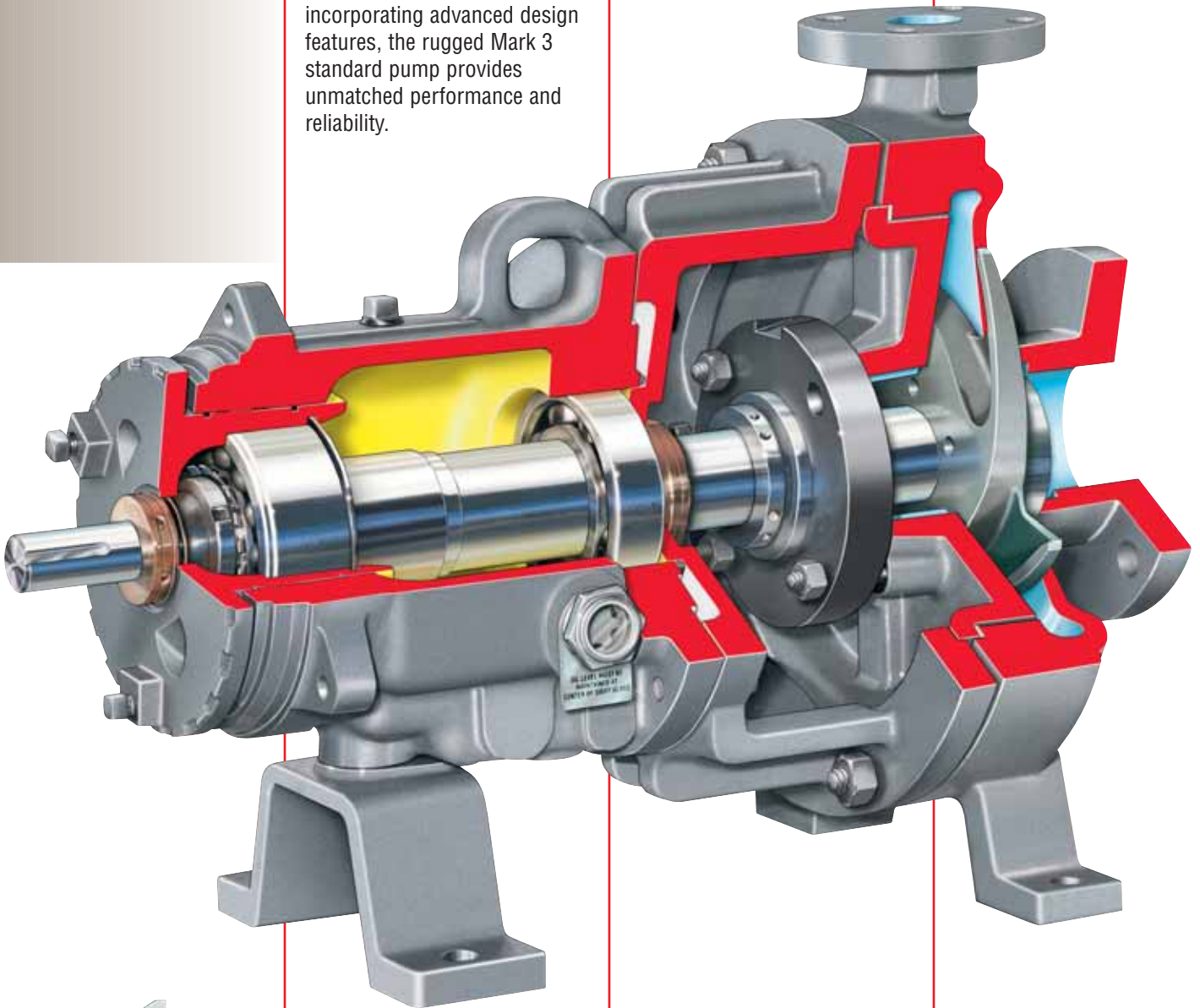

Unique Reverse Vane Impeller is the only impeller design that offers repeatable pump performance throughout the life of the pump. Open impellers available

SealSentry™ Seal Chambers feature unique flow modifiers to extend seal life and provide advanced self-flushing capability

External Micrometer Impeller Adjustment accurately sets impeller clearance in 20 seconds, in the shop or the field

Largest Shaft and Bearing Components in standard ANSI pumps extends bearing life and reduces shaft deflection and vibration



Truest Running ANSI Pump

The Mark 3 standard pump is engineered with four precision machined metal-to-metal fit locations – more than any other manufacturer.

- Precision machined metal-to-metal bearing carrier reduces tolerance stack-ups to improve shaft concentricity
- Superior to jackscrew designs which can cause cocking
- Extends bearing and mechanical seal life

Reliability and Performance Enhancing Features

- Precision investment cast reverse vane impeller offers low, predictable seal chamber pressure and repeatable pump performance
- External micrometer impeller adjustment reduces maintenance time and restores pump efficiency



- SealSentry seal chambers extend mechanical seal life and improve pump reliability
- Precision metal-to-metal fits improve concentricity and extend bearing and seal life
- Choice of corrosion-resistant materials prolongs pump life



SealSentry family of seal chambers features unique flow modifiers (FM) designed to extend mechanical seal life and increase pump reliability.

- Improves mechanical seal performance and reliability
- Permits use of less expensive seal and flush plan technology
- Improves pump reliability
- Vaalar Award winning design

Choice of Power Ends

- Standard Mark 3A power end with double lip oil seals and top vent/breather
- ANSI 3A™ power end (shown on page 8) featuring Inpro VBXX bearing isolators and a lifetime warranty

**Mark 3
Performance Curves**

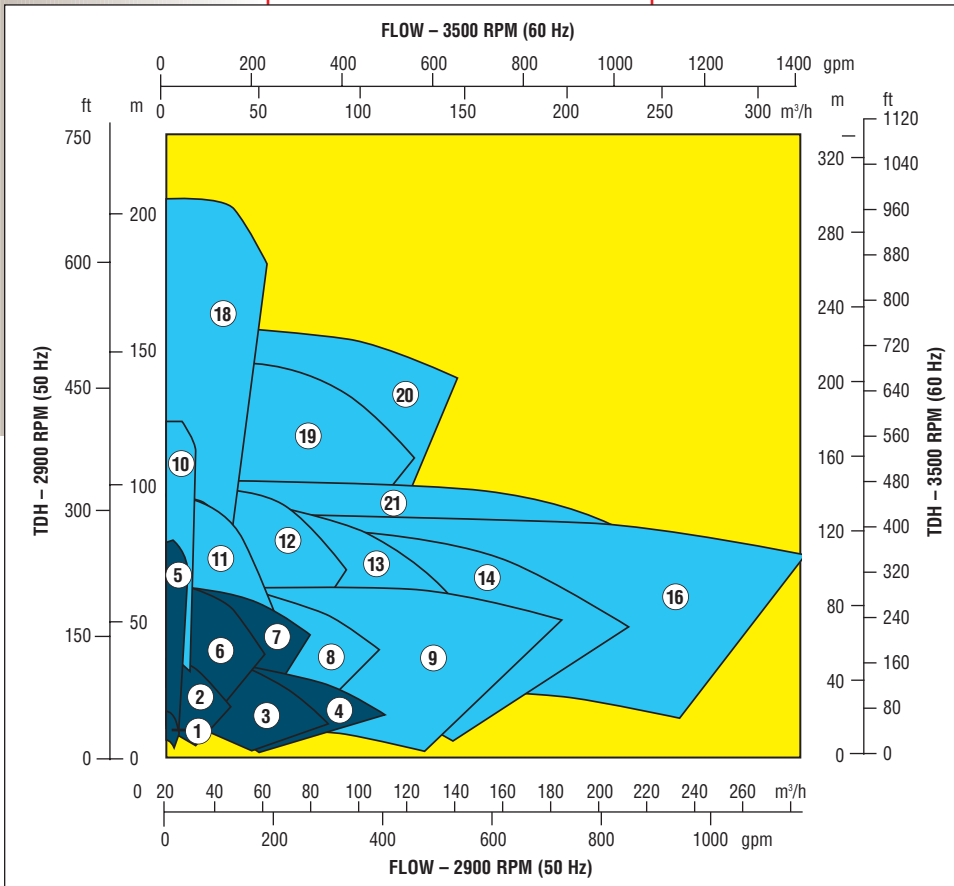

Mark 3 Standard Group 1

- ① 1½x1LF-4
- ② 1½x1-6
- ③ 3x1½-6
- ④ 3x2-6
- ⑤ 1½x1LF-8
- ⑥ 1½x1-8
- ⑦ 3x1½-8

Mark 3 Standard Group 2

- ⑧ 3x2-8
- ⑨ 4x3-8
- ⑩ 2x1LF-10
- ⑪ 2x1-10A
- ⑫ 3x1½-10A
- ⑬ 3x2-10A
- ⑭ 4x3-10
- ⑮ 4x3-10H
- ⑯ 6x4-10
- ⑰ 6x4-10H
- ⑱ 3x1½LF-13
- ⑲ 3x1½-13
- ⑳ 3x2-13
- ㉑ 4x3-13
- ㉒ 4x3-13HH
- ㉓ 6x4-13A

Mark 3 Standard Group 3

- ⑳ 8x6-14A
- ㉕ 10x8-14
- ㉖ 6x4-16
- ㉗ 8x6-16A
- ㉘ 10x8-16
- ㉙ 10x8-16H
- ㉚ 10x8-17*

*Max. speed 1450 RPM

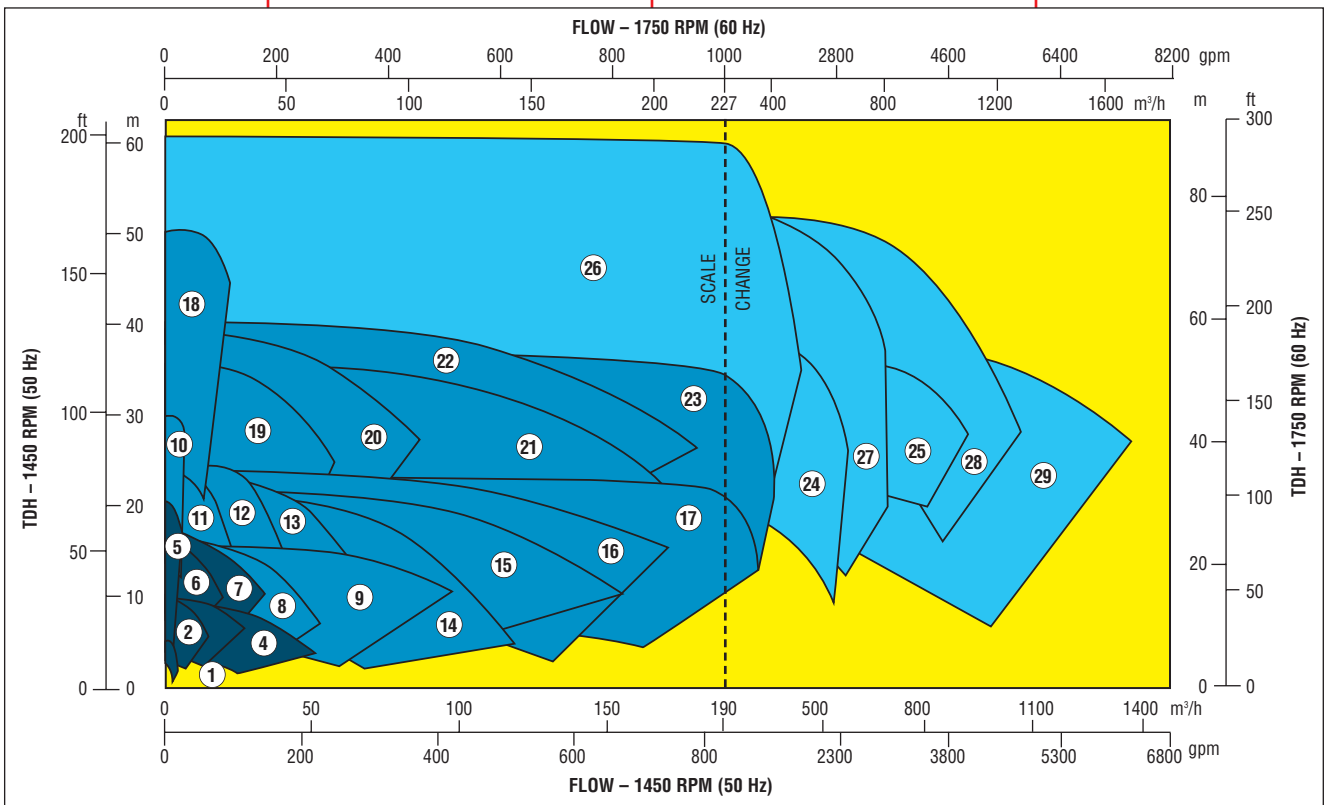

Mark 3 Interchangeability

The 30 pumps in the Mark 3 family are built with only three different power frames.

SealSentry provides a choice of five different seal chamber options to best meet your specific needs.

Pumps delivered worldwide are manufactured in ISO 9001 certified Flowserve facilities.



Quality System Certificate

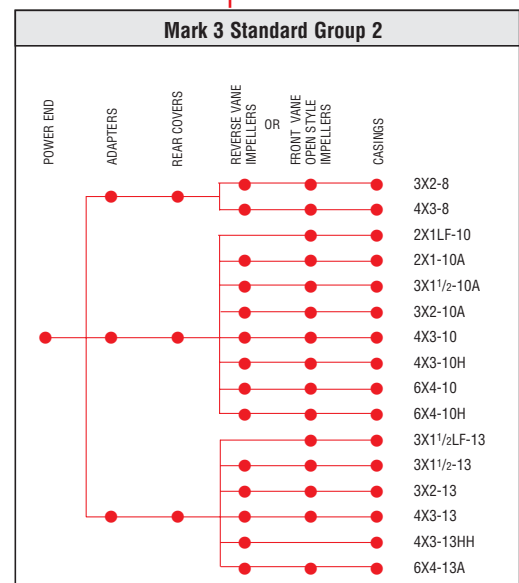
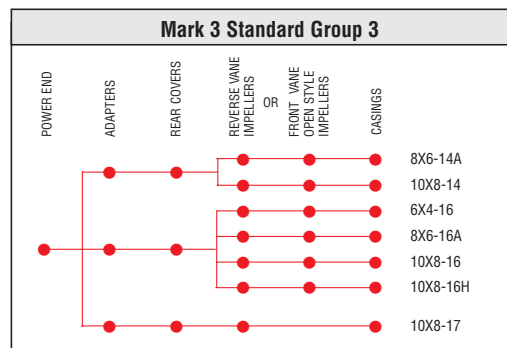
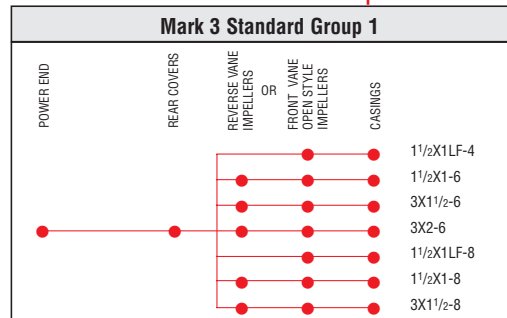

PROS+
PROS+ proposal and order system is the most comprehensive and user friendly pump selection program in the industry. This software ensures correct sizing and selection of Flowserve pumps to best suit your process application needs.

Pros+ is available from your local sales representative or on-line at www.flowserve.com.

PROS+ SE

Flowserve Pump Division

Including:

- Centrifugal Pump Fundamentals
- API-610, 8th Ed. Centrifugal Pump Datasheet Program

- Proprietary knowledge-based pump selection program accessing over 95 EPD product lines
- Valuable tool to facilitate process design and engineering estimates
- Electronic communication of selection and quotation data

**Mark 3
Power Ends**

Flowserve offers a choice of power ends: the standard Mark 3A or the optional ANSI 3A™ (shown below).

Standard Mark 3A Power End

- Double row angular contact outboard/single row, deep groove inboard bearings for excellent axial and radial load support
- External micrometer impeller adjustment
- Double lip oil seals
- Top mounted vent and oil filler
- Constant level oiler
- Large 25 mm (1 in) diameter reflective sight glass
- Optional magnetic drain plug
- Optional oil slinger

Unique, External Micrometer Impeller Adjustment enables accurate impeller clearance setting in 20 seconds

- Superior to jackscrews
- Protected with O-rings

ANSI 3A Power End

The ANSI 3A power end is so advanced it carries a lifetime warranty*.

- Certified *clean room* assembly
- Inpro/Seal's VBXX non-contact Vapor Block Bearing Isolators keep lubricants in and contaminants out
- Top vent replaced with plug

- Lubrication options
 - Oil mist systems
 - Shielded and grease lubricated bearings (three-year bearing guarantee)
- Rigid foot design

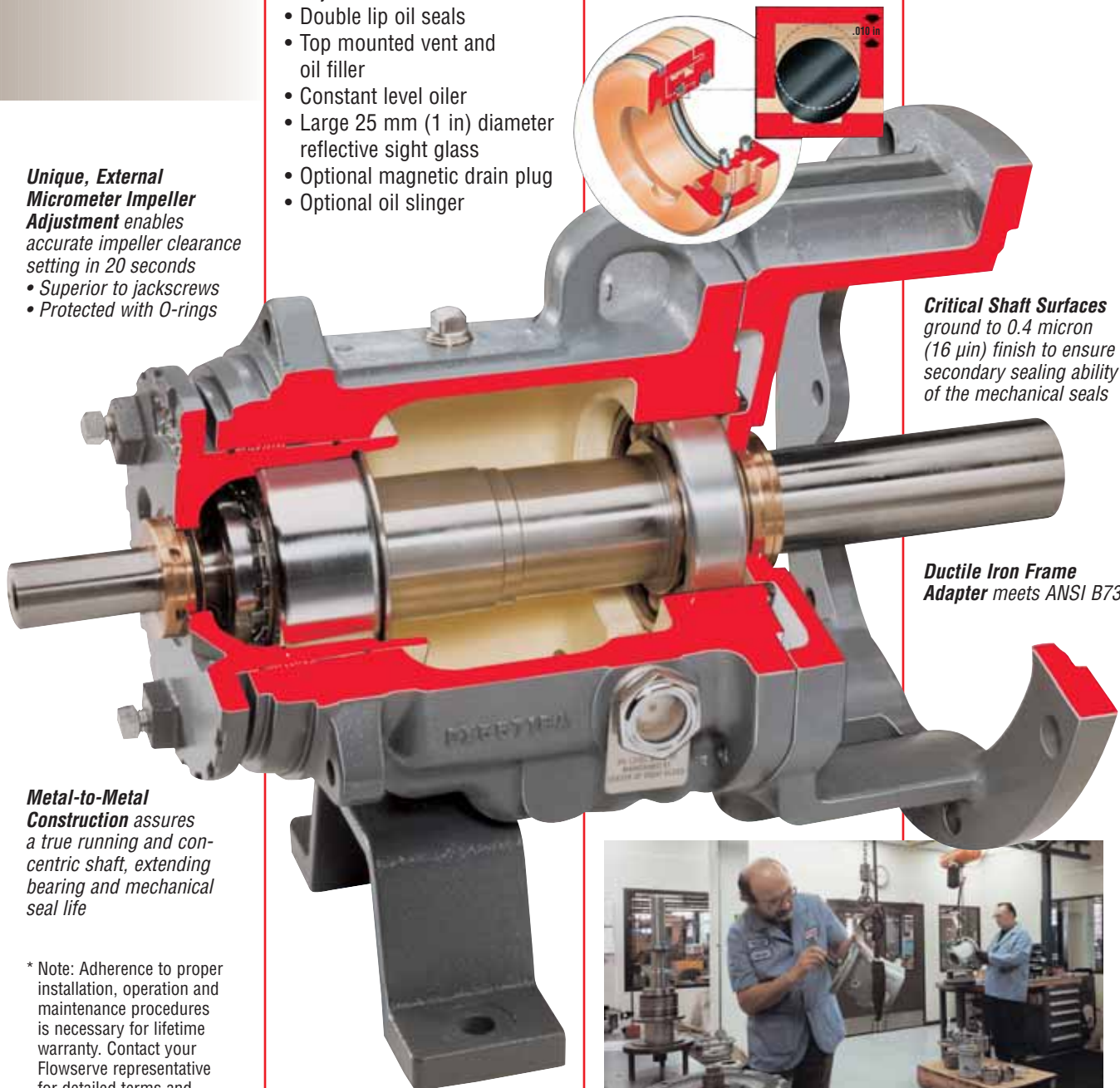

Critical Shaft Surfaces ground to 0.4 micron (16 µin) finish to ensure secondary sealing ability of the mechanical seals

Ductile Iron Frame Adapter meets ANSI B73.1

Metal-to-Metal Construction assures a true running and concentric shaft, extending bearing and mechanical seal life

* Note: Adherence to proper installation, operation and maintenance procedures is necessary for lifetime warranty. Contact your Flowserve representative for detailed terms and conditions.



**Mark 3
Heavy-Duty
Shaft and
Bearings**

**The Heart of the Pump:
Shaft and Bearing Design**

Flowserve offers the largest shaft and bearing components available in standard ANSI pumps. The following comparison of a Mark 3 Group 2 power end with that of a major competitor demonstrates the benefits of heavy-duty design.

**Table 1
Bearing Comparison**

| Group II | I.B. Bearing | Dynamic Load Rating | O.B. Bearing | Dynamic Load Rating |
|-------------------------|--------------|------------------------|--------------|------------------------|
| Flowserve | 6310 | 6078 kg (13 400 lb) | 5310 | 8709 kg (19 200 lb) |
| Major Competitor | 6309 | 5398 kg (11 900 lb) | 5309 | 7439 kg (16 400 lb) |

Prima³ bearings are designed to last up to 61% longer.

Bearings (see Table 1)
Greater load handling rating means extended bearing life.

Extended bearing life comparison is the ratio of the load ratings to the third power or:

$$I.B. = \left| \frac{6078}{5398} \right|^3 = 1.43 (+43\%)$$

$$O.B. = \left| \frac{8709}{7439} \right|^3 = 1.61 (+61\%)$$

**Table 2
Deflection Comparison**

| Group II | Overhang Length | Solid Shaft Diameter | Deflection Index | Shaft Dia. w/sleeve | Deflection Index |
|-------------------------|----------------------|----------------------|------------------|---------------------|------------------|
| Flowserve | 189 mm (7.687 in) | 48 mm (1.875 in) | 37 | 38 mm (1.5 in) | 90 |
| Major Competitor | 213 mm (8.375 in) | 45 mm (1.75 in) | 63 | 38 mm (1.5 in) | 116 |

43-252% greater stiffness, indicated by lower index numbers, results in improved performance and reliability.

Shafts (see Table 2)
Solid shafts are recommended over shaft sleeves because they reduce the harmful effects of deflection and vibration. While shaft sleeves may simplify maintenance, solid shafts reduce it.

Proper selection of wet-end materials of construction and mechanical seal design offset positive features of the shaft sleeve option.

The formula $I = L^3/D^4$ offers an index of deflection to compare pump designs where:
I = index of deflection
L = length of shaft overhang from bearing
D = rigid shaft diameter

Note: The Deflection Index provides an approximate comparison of shaft stiffness. A detailed analysis should be made to determine actual shaft deflection.

Unique External Micrometer Impeller Adjustment reduces maintenance time and, most importantly, is precisely accurate.



Simply loosen the setscrews. Using a wrench rotate the bearing carrier counterclockwise until the impeller lightly touches the rear cover plate.



Select the impeller setting. Each notch on the carrier ring represents exactly 0.10 mm (0.004 in) of clearance. For an impeller setting of 0.5 mm (0.020 in) count five notches counterclockwise.



Move the bearing carrier clockwise the selected number of notches. Tighten the setscrews and check the impeller clearance with the feeler gauge.

**Mark 3
SealSentry
Chambers**

Advanced Mark 3 SealSentry Design Technology

SealSentry chambers maximize seal life, reduce pump operating costs and improve pump reliability.

- Extend seal life
 - Self-flushing
 - Self-venting
 - Self-draining
- Reduce maintenance and repair costs
- Permit use of less expensive seals and flush plans
 - Flush plans 11, 32, 52, 53, etc. can be eliminated
- Increase mechanical seal life
- Provide a safer environment for personnel

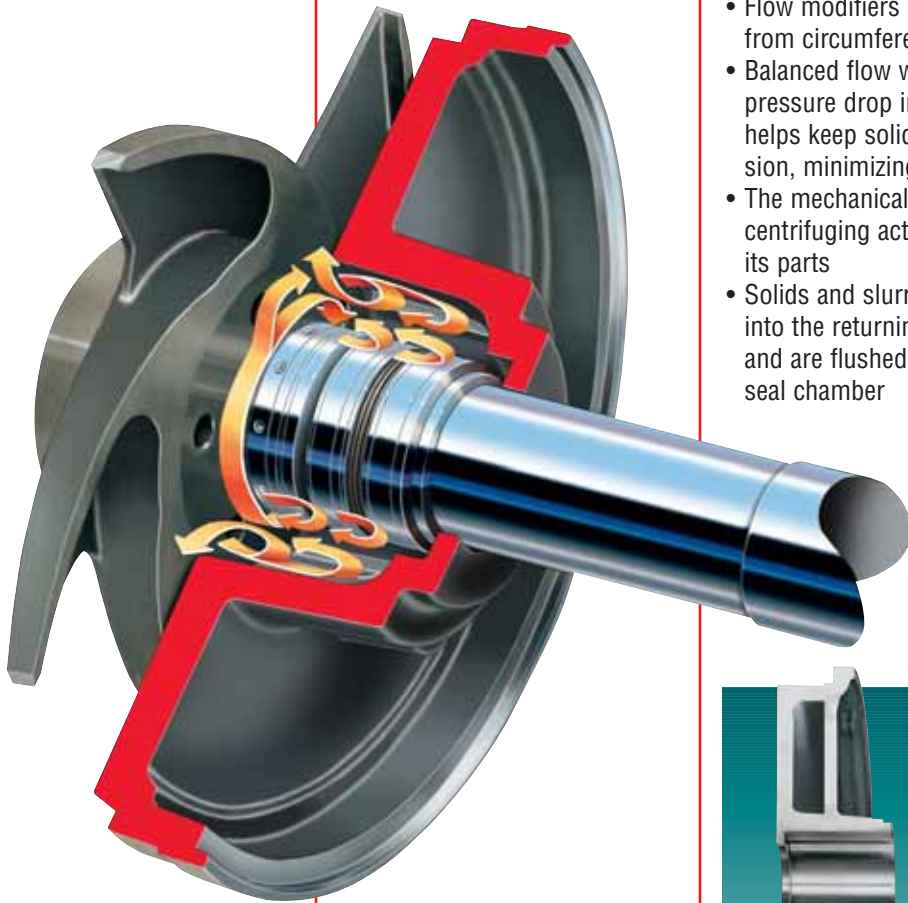

Flow Modifiers (FM) Extend Mechanical Seal MTBPM

- Flow modifiers redirect flow from circumferential to axial
- Balanced flow with low pressure drop in the chamber helps keep solids in suspension, minimizing erosion
- The mechanical seal creates a centrifuging action away from its parts
- Solids and slurry merge into the returning flow path and are flushed out of the seal chamber



Available Jacketed Seal Chambers

- are designed for effective heat transfer in the seal chamber area or across the entire surface area of the process fluid.
- Use the jacketed cylindrical bore when seal chamber cooling is the objective
 - Use the jacketed FM seal chamber when protection of the process temperature is important



Jacketed Seal Chambers

**Mark 3
SealSentry
Chambers**

The SealSentry family of seal chambers offers three FM (flow modifier) and two cylindrical bore (CB) options.

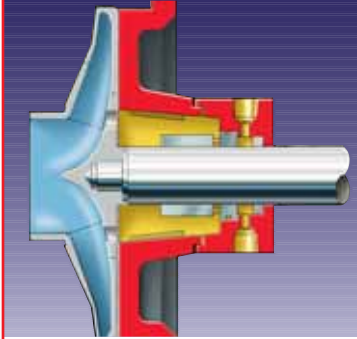

FML
Designed with a large gland bolt and gasket circles, the FML is preferred for most applications.

- Single internal cartridge seals
- Dual internal/external cartridge seals
- Single internal component seals with flexibly mounted seats
- Dual internal “true” tandem design cartridge seals

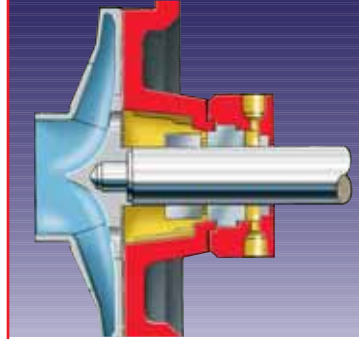

FMS
Similar to the FML, the FMS accommodates seals with small gland bolt and gasket circles.

- Single seals with all seat mounting configurations can be installed

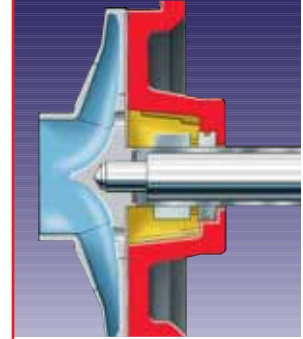

FMI
The FMI incorporates a cast-in integral gland.

- Single internal, flexibly mounted seals
- Sanitary-type applications
- Utilizes sleeve for seal setting and fast installation

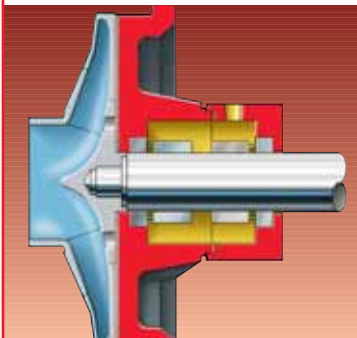

CBL
Designed with an oversized cylindrical step bore, the CBL is ideal for seals with large gland bolt and gasket circles.

- Dual internal component seals isolate the seal chamber from the process with external source flush
- Single seal with throttle bushing and flush to boost pressure over flash point

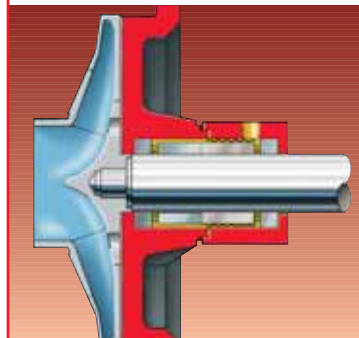

CBS
The CBS cylindrical bore seal chamber is designed for packing arrangements and conventional seals with small gland bolt and gasket circles.

**Mark 3
Impellers**

Flowserve Durco reverse vane impellers deliver unequalled efficiency and performance. This exclusive impeller design extends bearing and seal life.

- **Low, Predictable Seal Chamber Pressure and Thrust Loads** resulting from back vane pumping action and balance holes
- **Lowest Required NPSH** of any standard pump
- **Rear Cover Plate Wear Surface** as the flow path exits the rear of the impeller. Abrasive wear is on the rear cover rather than the more expensive casing

- **In-shop Impeller Adjustment** with the only impeller design that takes full advantage of the back pull-out feature. Since the critical running clearance is set between the rear of the impeller and the rear cover plate, both impeller and mechanical seal settings can be done in the shop, “on the bench,” instead of under adverse field conditions
- **Repeatable Performance Assurance** with the only impeller design that offers *repeatable* seal chamber pressures and bearing thrust loads

Exclusive Reverse Vane Impeller with balance holes offers important performance enhancing, maintenance-reducing advantages.



Front Vane Open Style Impeller is fully interchangeable with the reverse vane impeller. Excellent choice for fibrous, stringy materials and certain applications requiring high shear against the casing.

Recessed Impeller pumps offer excellent solids-handling capabilities. See page 28.



In-shop Impeller Adjustment is practical as well as productive.

Low Predictable Seal Chamber pressure means longer seal life

Clearance is set to the rear cover in the shop – not to the casing which is left in the piping

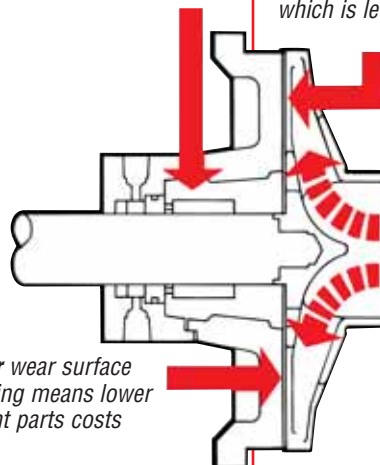

Lowest Overall required NPSH of any standard pump

Rear Cover wear surface versus casing means lower replacement parts costs



Radial Vane Impeller is available for low-flow, high-head applications. See pages 22 and 23.

Reverse Vane Impeller

has only one set of pumping vanes and one critical tolerance location – between the impeller and rear cover – to establish:

- Performance
- Efficiencies
- Seal chamber pressures
- Thrust/axial loads

Since an impeller can only be set in one direction, the reverse vane impeller has inherent advantages.

Only Flowserve Durco reverse vane impellers offer repeatable performance after wear and impeller adjustment.

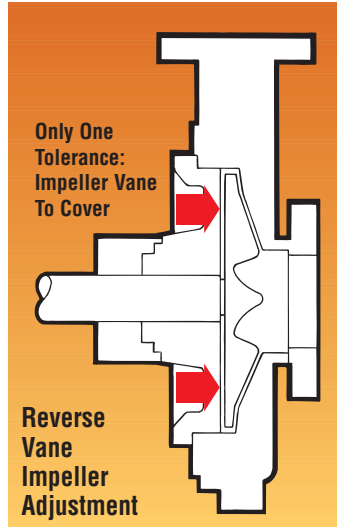

Performance Life Cycle: Durco Reverse Vane Impeller with Balance Holes

Effects of Wear

- Thrust loads decrease as seal chamber gap widens
- Chamber pressure increases as gap widens

Effects of Impeller Adjustment to Seal Chamber

- Original pressures and loads re-established after adjustment
- Repeatable cycle life

Reverse Vane Impeller

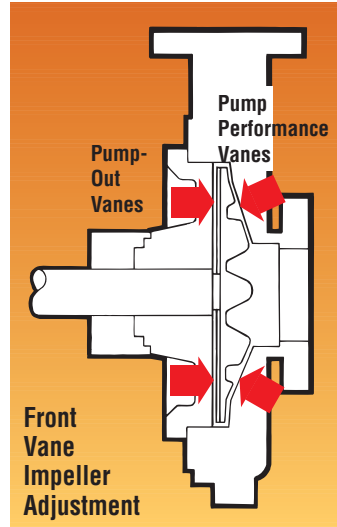
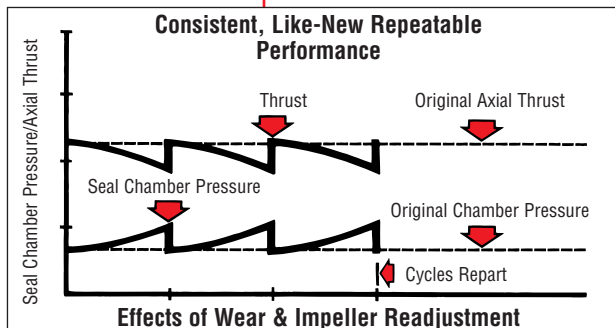

Performance Life Cycle: Front Vane Open Style Impeller with Pump Out Vanes

Effects of Wear

- Thrust loads increase as seal chamber gap widens
- Chamber pressure increases as gap widens

Effects of Impeller Adjustment to Casing

- Chamber pressures and bearing loads increase after each adjustment
- Non-repeatable cycle life

Front Vane Open Style Impeller

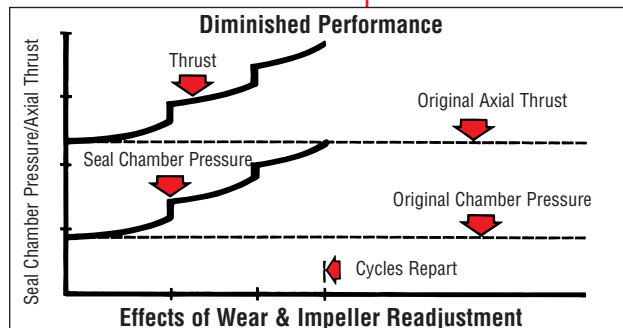

Front Vane Open Style Impeller

has two sets of pumping vanes and two critical tolerance locations:

- The front vane of the impeller clearance to the casing establishes:
 - performance
 - efficiencies
- The impeller pump out vanes clearance to the rear cover establishes:
 - seal chamber pressures and seal life
 - thrust loads and bearing life

An impeller cannot be adjusted to two locations.

Seal and bearing life are reduced due to increased loads after wear and maintenance adjustment.

**Mark 3
Shafts and
Sleeves**

Mark 3 shafts and sleeves are designed to improve pump reliability.

Shaft Choices

Friction-Welded: a steel power end friction-welded to a solid alloy wet end

Composite: a steel shaft end-to-end with an integral (i.e., not replaceable) sleeve of DC8, SD77 high silicon iron, ceramic (alumina or zirconia)

Solid: steel end-to-end or stainless alloy end-to-end

Hook Sleeve: a steel shaft end-to-end or a steel power end friction-welded to a stainless wet end accommodating a hook sleeve

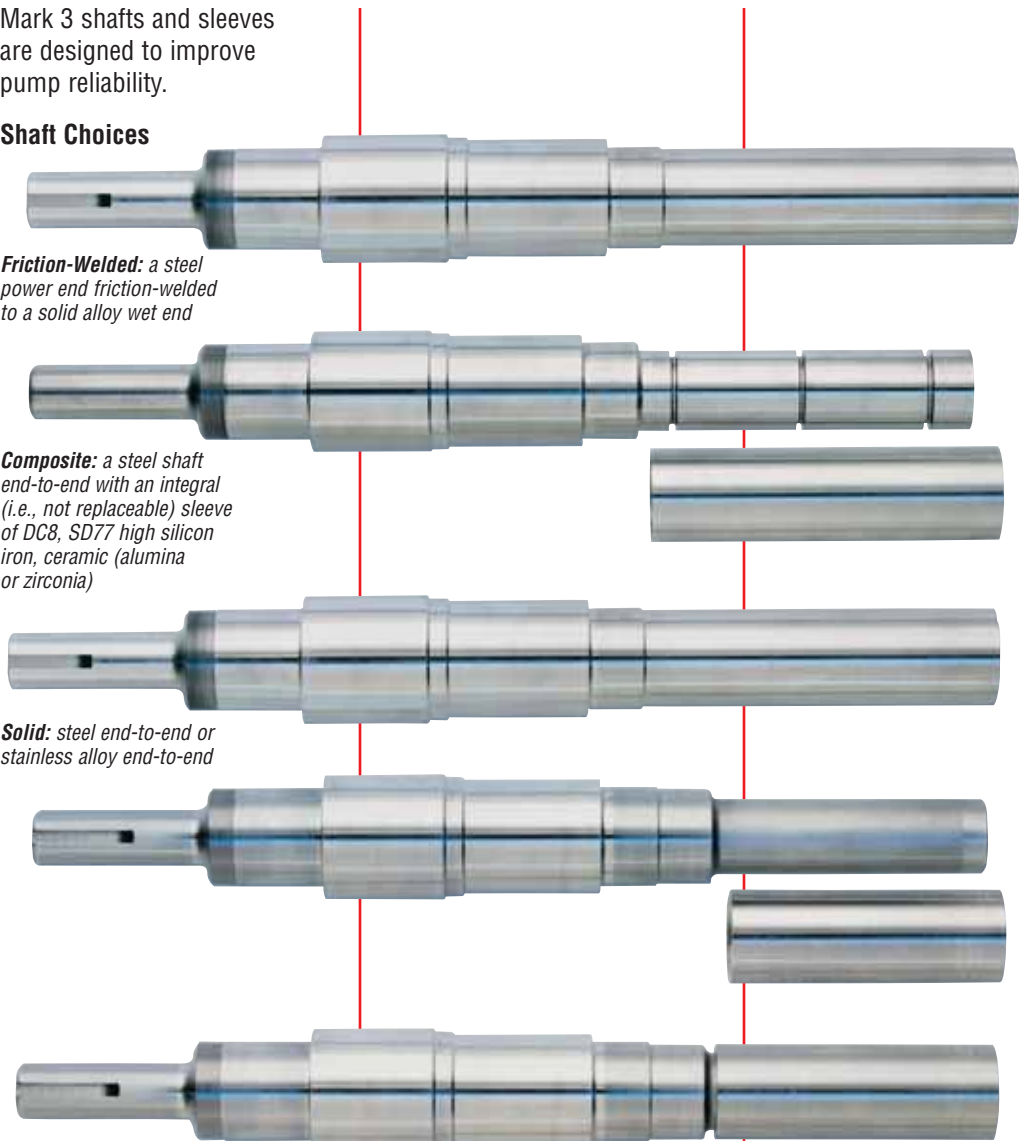

Shaft Material Choices
investment cast or high alloy bar stock available in a wide range of materials.

Flowserve recommends the use of solid shafts rather than shaft sleeves to reduce the harmful effects of deflection and vibration. Shaft sleeves may simplify maintenance but solid shafts reduce it.

- ① Radiused "sled-runner" keyways improve strength at this stress point.
- ② Offset keyways aid shaft balance.
- ③ Alloy identification on every shaft and sleeve ensures that the right parts go in every time.
- ④ Large radii fillets add strength.
- ⑤ Accurate machining under bearings ensures perfect bearing fits without vibration or hot running.
- ⑥ Run-out of <math><0.001\text{ in (0.03 mm)}</math> at mechanical seal allows seal faces to run true.

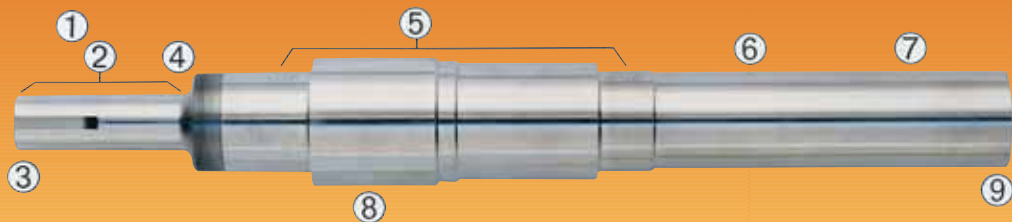

- ⑦ Critical surfaces ground to a surface finish of 0.4 micron in (16 μ) ensure the secondary sealing ability of mechanical seals.
- ⑧ Steel power ends handle higher horsepower loads than stainless.
- ⑨ Minimally radiused edges ensure full contact with impeller for reduced run-out.

**Mark 3
Pump Parts and
Alloy Materials**

Specify genuine Mark 3 parts for your pump maintenance needs.

In addition to sure-bet maintenance savings only Flowserve offers:

- Parts that are guaranteed to fit...to last... and to perform
- Lifetime casting guarantee
- Quality assured safety for operating and maintenance personnel

- Off-the-shelf availability from a computer-linked network
- Machining and modification service for special orders
- 24-hour emergency service
- Application and materials expertise
- Complete analysis of your maintenance needs with recommended parts inventory



Flowserve foundries are widely regarded as among the best in the world pouring alloys from ductile iron to stainless steels to light reactive alloys such as titanium. All wet-end Mark 3 castings carry a limited lifetime guarantee.

Attesting to the world-class quality of its castings, Flowserve was the first high alloy foundry in the United States of America to have earned approval by Germany's Technischer Überwachungs Verein (TUV).

Flowserve Durco Alloy Materials

| Designation | Symbol | ACI Designation | Equivalent Wrought Designation | ASTM Specifications* |
|---------------|--------|-----------------|--------------------------------|----------------------|
| Ductile Iron | DCI | None | None | A395 |
| Carbon Steel | DS | None | Carbon Steel | A216 Gr. WCB |
| CF-8M | D4 | CF8M | 316 | A744, Gr. CF-8M |
| Durcomet 100 | CD4M | CD4MCuN | Ferralium® 255 | A995, Gr. 1B |
| Durimet 20 | D20 | CN7M | Alloy 20 | A744, Gr. CN-7M |
| Durcomet 5 | DV | None | None | None |
| CY-40 | DINC | CY40 | Inconel® 600 | A494, Gr. CY-40 |
| M-35 | DM | M351 | Monel® 400 | A494, Gr. M-35-1 |
| Nickel | DNI | CZ100 | Nickel 200 | A494, Gr. CZ-100 |
| Chlorimet 2 | DC2 | N7M | Hastelloy® B-2 | A494, Gr. N-7M |
| Chlorimet 3 | DC3 | CW6M | Hastelloy® C-276 | A494, Gr. CW-6M |
| Duriron® | D | None | None | A518, Gr. 1 |
| Durichlor 51® | D51 | None | None | A518, Gr. 2 |
| Superchlor® | SD77 | None | None | None |
| DC-8 | DC8 | None | None | None |
| Titanium | Ti | None | Titanium | B367, Gr. C-3 |
| Titanium-Pd | Ti-Pd | None | Titanium-Pd | B367, Gr. C-8A |
| Zirconium | Zr | None | Zirconium | B752, Gr. 702C |

*Alloys conform to the chemical and mechanical requirements of the latest edition of the ASTM specification.
 © Duriron, Durichlor 51 and Superchlor are registered trademarks of Flowserve Corporation.
 © Ferralium is a registered trademark of Langley Alloys.
 © Hastelloy is a registered trademark of Haynes International, Inc.
 © Inconel and Monel are registered trademarks of International Nickel Co. Inc.

Mark 3 Pre-Engineered Baseplate Designs

Extend Pump and Seal Life at Reduced Cost

Flowserve offers five pre-engineered baseplate designs to improve pump performance and reduce costs (see page 17). Flowserve pre-engineered baseplates extend pump and seal life by reducing internal pump stress and vibrations. That is why Flowserve recommends reinforced rigid baseplates.

Plus, customers who know the value of pre-engineered and reinforced baseplates help avoid potential confusion in specification interpretation, delays in shipments and added costs.

Flowserve offers a broad range of metal and non-metallic, grout and stilt mounted designs and standard options. This provides broad flexibility in choosing the baseplate that best meets application needs and operating budget.



| Item No. | Standard Options | Type A | | Type B | Type C | Type D | Type D with Rim | Type E |
|----------|--|----------|------|--------|--------|--------|-----------------|--------|
| | | Gp 1 & 2 | Gp 3 | | | | | |
| 1 | Machined coplanar mounting surfaces to 0.17 mm/m (0.002 in/ft) with 3.2 micron (125 μ in) finish | O | O | O | O | O | O | Y |
| 2 | Added structural (cross member) support | N | N | Y | Y | Y | Y | Y |
| 3 | Added torsional support with end caps | NR | Y | Y | D | O | O | Y |
| 4 | Tapped holes for four (4) motor adjuster bolts | O | O | O | Y | O | O | Y |
| 5 | Four (4) - SS transverse jack bolts - motor adjusters | O | O | O | Y | O | O | Y |
| 6 | Sloped surface to an integral drain | N | N | C | N | N | N | Y |
| 7 | Integral sloped drip rim around base | N | N | N | N | N | Y | Y |
| 8 | 102 mm (4 in) diameter grout holes - max. 762 mm (30 in) run to vent | Y | Y | Y | N | Y | Y | Y |
| 9 | 13 mm (1/2 in) vent holes at corner of each chamber | NR | O | NR | NA | Y | Y | Y |
| 10 | Lower surface shaped to anchor in grout | N | N | N | NA | Y | Y | Y |
| 11 | Integral lifting eyes at four (4) corners | O | Y | O | O | Y | Y | Y |
| 12 | Tapped leveling holes four (4) corners | O | O | N | S | Y | Y | Y |
| 13 | Continuous seam weld construction | NA | Y | NA | O | Y | Y | Y |
| 14 | Welded raised lip around grout hole(s) | NR | NR | NR | NA | NR | NR | O |
| 15 | Stilt mounting options with floor cups | NR | NR | O | Y | D | D | D |
| 16 | Spring mounted load designs | NA | NA | O | O | D | D | D |
| 17 | Catch basin (304SS or other materials) | O | O | O | O | O | NR | Y |
| 18 | Option for eight (8) total motor adjusters | D | D | O | D | D | D | Y |
| 19 | Dimensions to ANSI B73.1 | Y | Y | Y | Y | Y | Y | Y |

Y = Standard N = Not available NR = Not recommended
 O = Optional NA = Not applicable C = Sloped catch basin with 25 mm (1 in) drain (option)

D = Needs design time
 S = Stilts for leveling

See page 17 for model descriptions

Mark 3 Baseplates

Flowserve offers a family of five types of pre-engineered baseplate designs to extend pump life and reduce costs.

Type A

Standard ANSI baseplate; foundation or limited stress stilt mounted.

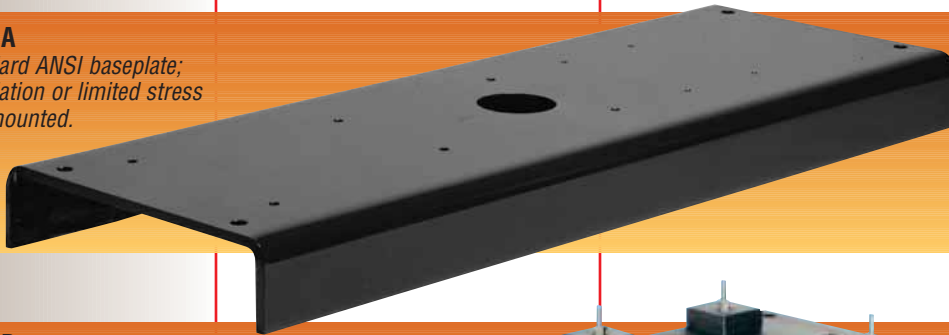

Type B

Polybase™ baseplate; foundation or stilt mounted.



Type C

Reinforced baseplate; stilt mounted.



Type D

Reinforced baseplate; foundation mounted; with optional drip rim.



Type E

Heavy-duty, foundation mounted baseplate; complies with PIP RESP 002.



Reducing Internal Stress and Vibration Extends the Life of Pump and Motor Packages

Pump users specify rigid baseplate designs to:

- Provide torsional lateral and longitudinal rigidity
- Improve vibration dampening
- Protect against transit damage
- Resist twisting during installation
- Maintain shaft alignment
- Reduce installation and shaft alignment time
- Reduce diaphragming or separation from grout
- Improve pump, motor and seal reliability
- Reduce total life cycle pump, motor and seal costs

Rigid Design Begins With Thick Plate Construction

Metal baseplate sizes:

- 139 to 258 feature 13 mm (1/2 in) steel plate construction
- 264 to 280 feature 16 mm (5/8 in) steel plate construction
- 368 to 398 feature 19 mm (3/4 in) steel plate construction

Polybase baseplates are constructed of 76 mm (3 in) to 102 mm (4 in) solid polymer concrete. Baseplate types B, C, D and E are reinforced with added structural support for improved rigidity.

Polybase™ Solid Polymer Concrete Baseplate

Polybase™ and Polybloc™ Solid Polymer Concrete Adjustment System

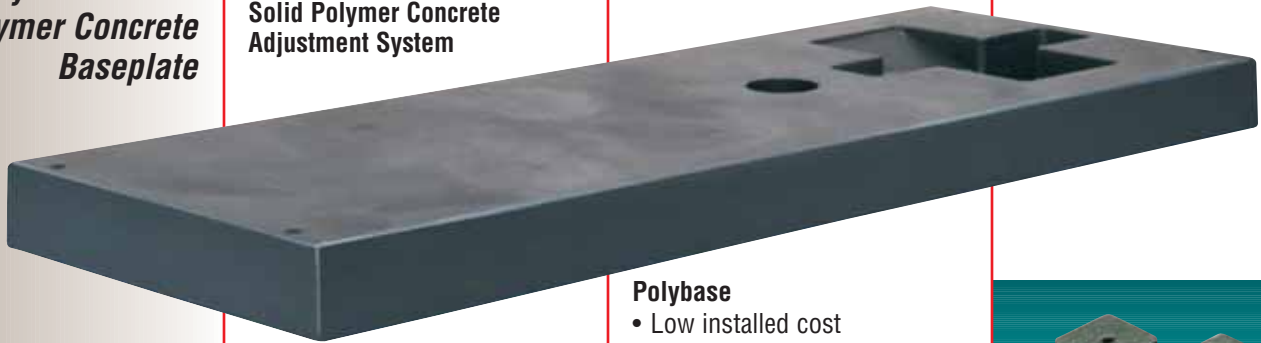

Type B – Polybase baseplate



Baseplates are Fundamental to Extending Pump Life
 The test stand provided three corner support of the ungrouted baseplates. The addition of weights on the unsupported fourth corner caused baseplate distortion. This distortion resulted in measurable shaft movement that can cause problems with field installations and negatively affect pump reliability and life.

The twist test is a means of comparing rigid baseplate designs. Correctly installed rigid baseplates should not experience these twist effects. For more information about the results of baseplate testing contact your local Flowserve sales representative.

Polybase

- Low installed cost
- Superior vibration dampening
- Corrosion resistant
- Superior resistance to twisting or diaphragming
- Optional catch basin and grout holes
- Inserts available for alternate equipment configuration requirements



Polybloc – Motor Mounting Block

- Flatter and more repeatable height tolerances than steel
- Corrosion resistant
- Superior vibration dampening
- Full foot support (no overhang)
- Shown with optional bloc-lock and fastener support
- Available for other pump and motor or alternate equipment applications

Baseplate Rigidity Test – Twist Mode

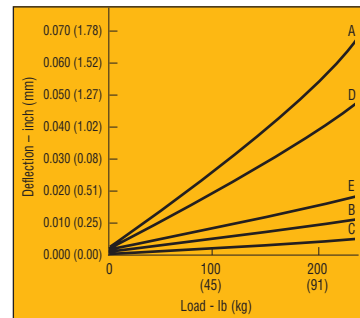

Maximum Parallel Shaft Deflection at Applied Force

| | |
|--------|--------------------|
| Type A | 0.022 in (0.56 mm) |
| Type B | 0.004 in (0.10 mm) |
| Type C | 0.003 in (0.08 mm) |
| Type D | 0.016 in (0.41 mm) |
| Type E | 0.005 in (0.13 mm) |

Vibration Damping of Polymer Concrete Versus Cast Iron

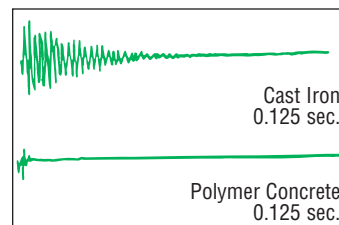

8-Point Adjuster

- Allows precise motor adjustment to reduce alignment time
- Used with recessed bloc-lock device

© John F. Kane, Composites Institute, The Society of the Plastics Industry, Inc.

**Flowserve
Polyshield
Polymer
Baseplate and
Foundation
System**

The **Polyshield Baseplate and Foundation System** is the superior solution for cost-effective, high-performance pump installation. In one complete unit, it combines a traditional baseplate with a formed concrete foundation for pump-drive sets.

Benefits of Selecting the Polyshield Baseplate and Foundation System

- Time savings
 - Quick installation time
 - Reduces time span from receipt at jobsite to commissioning
- Cost savings
 - Reduces total installed cost
 - Dramatically minimizes field rework necessary to meet specifications
- Better performance and reliability
 - Extended pump life
 - Reduced vibration
 - Improved corrosion resistance
- Single structure convenience
 - One-piece construction
 - Flat mounting surfaces
 - One-piece motor mounting block

The Polyshield baseplate and foundation system can be combined with numerous pump designs, including:

- ISO and ANSI metallic and non-metallic
- Foot- and frame-mounted general industrial
- Foot-mounted between bearings
- API 610

Please see Bulletin PS-90-2 for more complete product information.

Product literature available at www.flowserve.com.

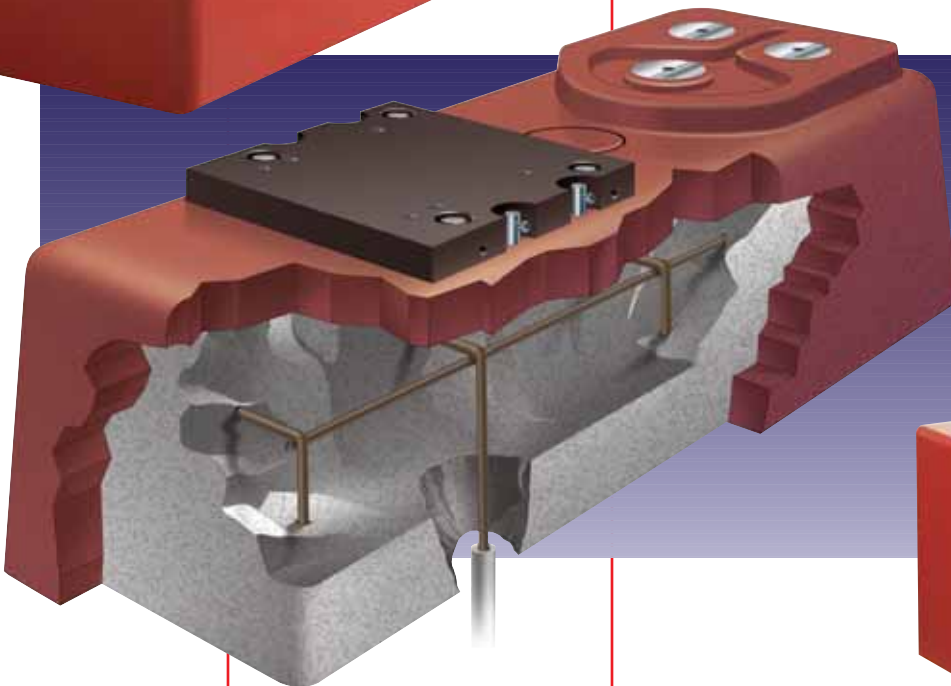
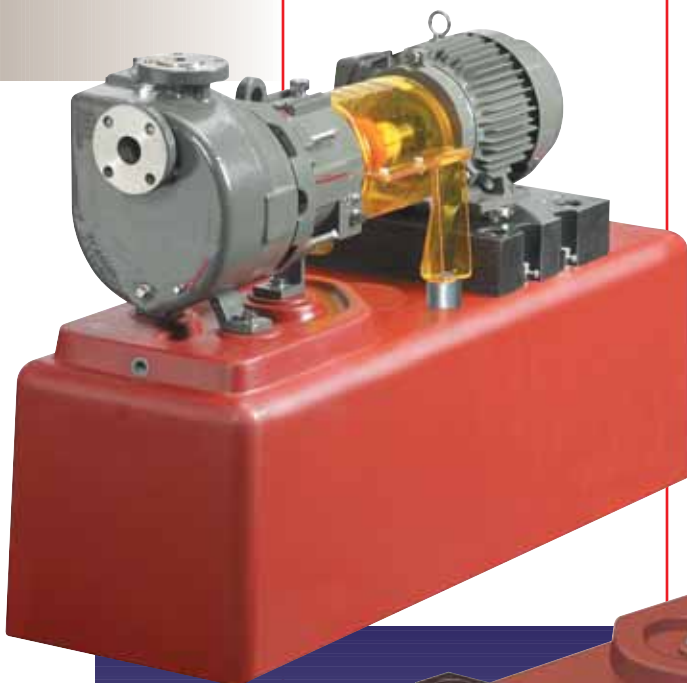

Options to Solve Application Problems

The Mark 3 offers unique design technologies and component options with superior pump application, installation, process and selection knowledge. These extend pump performance and increase reliability. Certain applications need technical advancement in pump design and performance-enhancing options for continued reliability.

Centerline Mounted Casings may be used to reduce loads caused by thermal expansion. Jacketed feet with inlet and outlet ports further ensure effective temperature control.



Jacketed Casings provide temperature control. Integral (shown) and bolt-on jackets available.



Ultralign™ Heavy-Duty, Rigid Design C-Flange Adapter

- Cantilevered motor shaft stays aligned with pump shaft even with undesirable movement caused by piping and temperature induced stress
- Eliminates foot mounting of motor and pump power end to the base, reducing soft foot, twisting and diaphragming problems
- 0.18 mm (0.007 in) nominal parallel shaft alignment 0.05 mm (0.002 in) with C-Plus precision alignment option
- <0.001 mm/mm (0.001 in/in) angular alignment

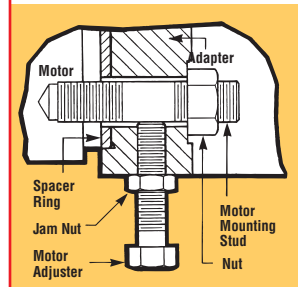

Unique C-Plus Precision Alignment System (Four Point) routinely delivers shaft alignments below 0.05 mm (0.002 in) in less than 30 minutes.

Adjustable Rigid Foot Mount is designed to support all normal loads and ensures accurate alignment to the baseplate and piping.

Available Stilt Mounted Baseplate provides relief of external pipe loads by allowing the assembly to move to the point of least resistance.

- Stilts can allow for improved pump alignment to process pipe
- Spring load option absorbs vibration and reduces need for pipe loops or expansion joints

ClearGuard and DurcoShield Pump Safety Accessories

ClearGuard and DurcoShield Non-metallic Safety Guards

ClearGuard and DurcoShield pump guards permit visual inspection of coupling and seal areas, respectively, while protecting personnel from potential safety hazards of rotating parts. Constructed of tough, durable, and transparent polycarbonate with UV light inhibitors, they are designed to withstand tough chemical processing environments.

ClearGuard Non-metallic Coupling Guard

meets machinery guard safety guideline. Nothing larger than 6 mm (0.24 in) in diameter can enter the shell. Furthermore, the ability to inspect the coupling through ClearGuard can provide early warning of deteriorating or malfunctioning components.

DurcoShield* Splash and Shaft Guard

is a one-piece shield that envelops the open areas between the bearing housing and casing. Suitable for applications to 150°C (300°F), DurcoShield protects users from:

- Process fluid spray
- Rotating shaft and seal components

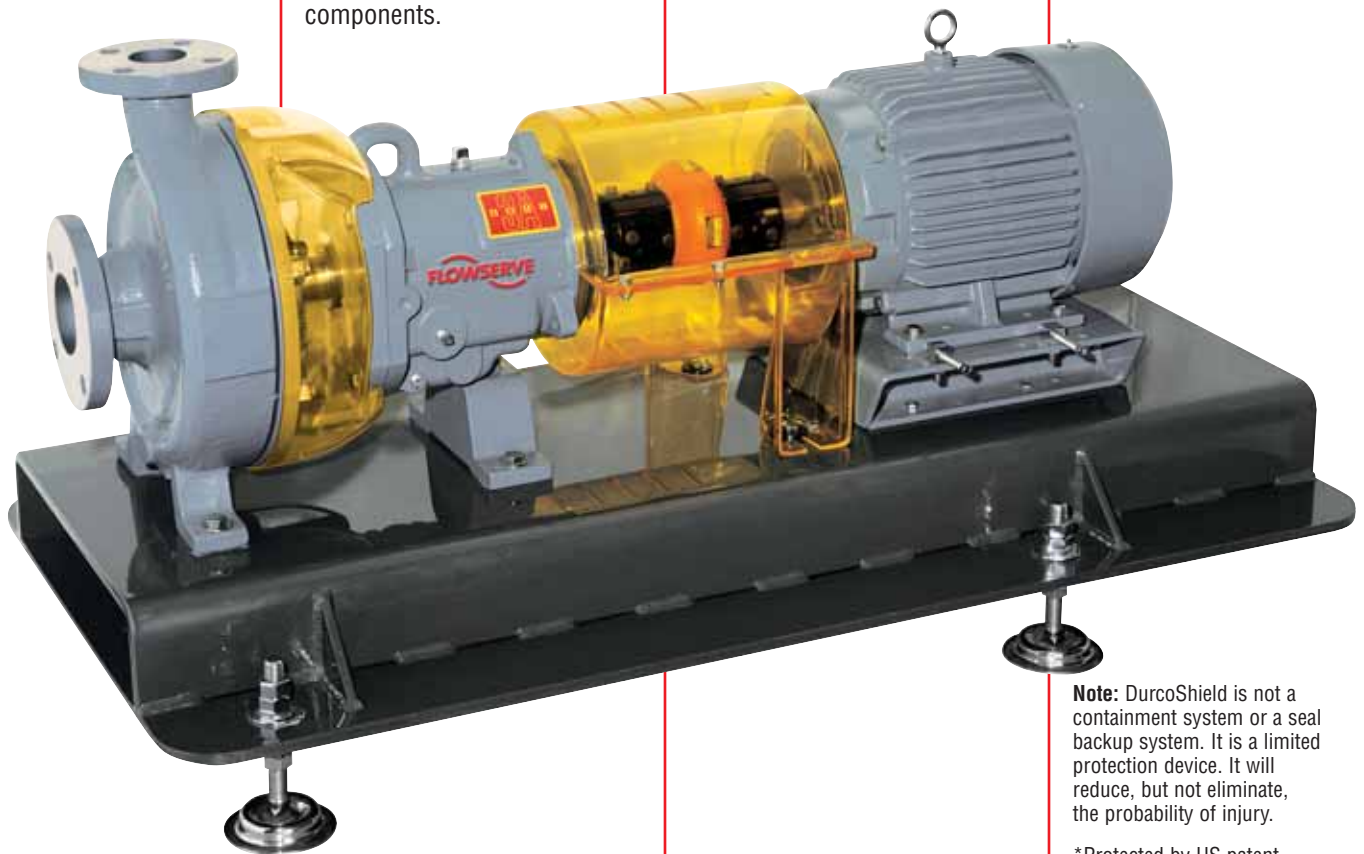

Note: DurcoShield is not a containment system or a seal backup system. It is a limited protection device. It will reduce, but not eliminate, the probability of injury.

*Protected by US patent number 5,807,086

**Mark 3
Lo-Flo™ Pump**

The Flowserve Mark 3 Lo-Flo pump is designed to improve pump reliability and performance in low-flow, high-head applications. The first pump manufacturer to introduce an ANSI standard low-flow, high-head pump, Flowserve developed its innovative radial vane impeller and circular, concentric casing to reduce radial loads and shaft vibration while extending bearing and mechanical seal life.

The Flowserve Mark 3 Lo-Flo pump conforms to ANSI B73.1 and is completely interchangeable with the industry-leading Mark 3A power end.

Operating Parameters

- Flows to 50 m³/h (220 gpm)
- Heads to 300 m (985 ft)
- Pressures to 31 bar (450 psi)
- Temperatures from -75°C (-100°F) to 370°C (700°F)

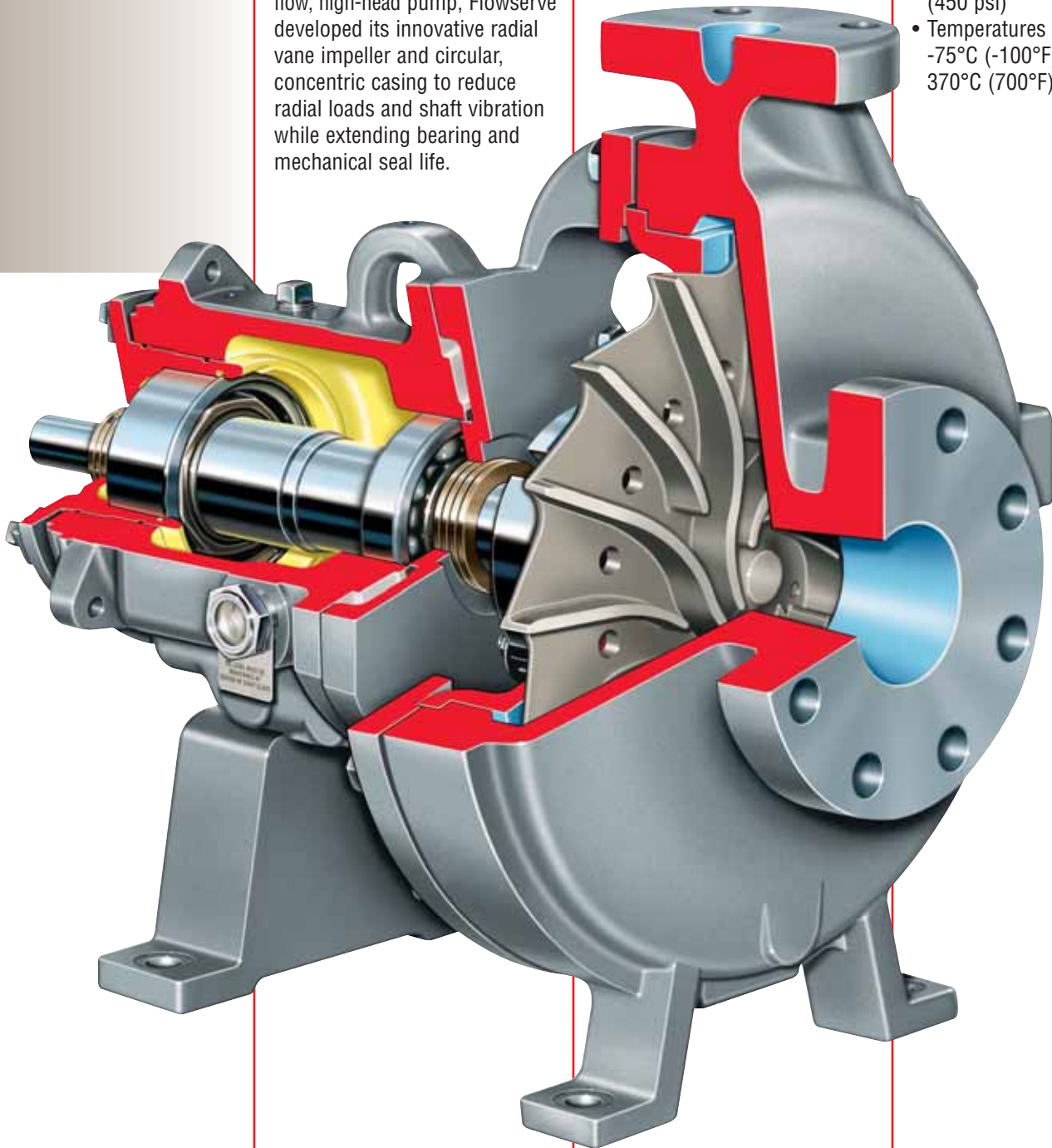

Radial Vane Impeller provides improved performance over a broader application range

Circular Concentric Casing reduces radial loads and vibration and extends bearing and seal life

SealSentry™ Seal Chambers extend seal life and provide advanced self-flushing ability

External Micrometer Impeller Adjustment accurately sets impeller clearance in 20 seconds, in the shop or the field

Innovative Radial Vane Impeller has a unique twist to provide superior performance in low-flow, high-head conditions.

Circular Concentric Casing is more hydraulically efficient at lower flow rates. An internal bypass drilled in the discharge without breaching the casing wall or creating a potential leak path. This helps to balance pressures.



Expanding Volute Casing

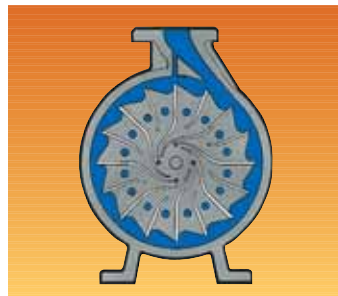

Circular Concentric Casing



Improved Performance and Reliability

The innovative radial vane impeller and circular, concentric casing of the Flowserve Durco Lo-Flo pump improve pump performance and reliability when compared to standard pumps. Furthermore, maintenance is reduced.

- Reduced radial loads up to 90% at low-flow conditions
- Minimized thrust loads
- Reduced NPSH requirements
- Reduced shaft vibration
- Extended bearing life
- Extended mechanical seal life
- Broadened application range

Four Sizes

- 1K1.5x1LF-4
- 1K1.5x1LF-8
- 2K2x1LF-10
- 2K3x1.5LF-13

Offered in a wide range of metallurgy to meet application needs.

Choice of Power Ends

- Standard Mark 3A power end with double lip oil seals and top vent/breather
- ANSI 3A™ power end (see page 8) featuring Inpro VBXX bearing isolators and up to a lifetime warranty

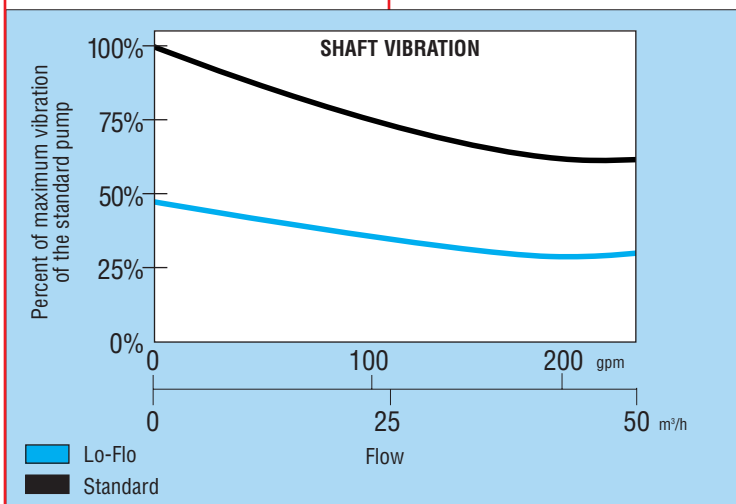

Reduced Vibration

Shaft vibration is a critical factor in both bearing and mechanical seal life. Reducing shaft vibration results in significantly improved pump performance and reliability.

**Mark 3
Sealmatic
Pump**

Dynamic Sealing

With the Flowserve Mark 3 Sealmatic pump, no mechanical seal is needed during operation. A dynamically sealing repeller (expeller) expels fluid from the seal chamber, making it ideal for hard to seal applications. Furthermore, the need for external flushing and process contamination control are eliminated.

The Sealmatic pump conforms to ANSI B73.1.

Applications

- Tough services where sealing is difficult
- Services where a flush is undesirable (e.g., evaporator feed)
- Continuous, around-the-clock applications
- Batch operations where a “run dry” condition might exist

Operating Parameters

- Flows to 1680 m³/h (7400 gpm)
- Heads to 230 m (750 ft)
- Pressures to 31 bar (450 psi)
- Temperatures from -75°C (-100°F) to 370°C (700°F)

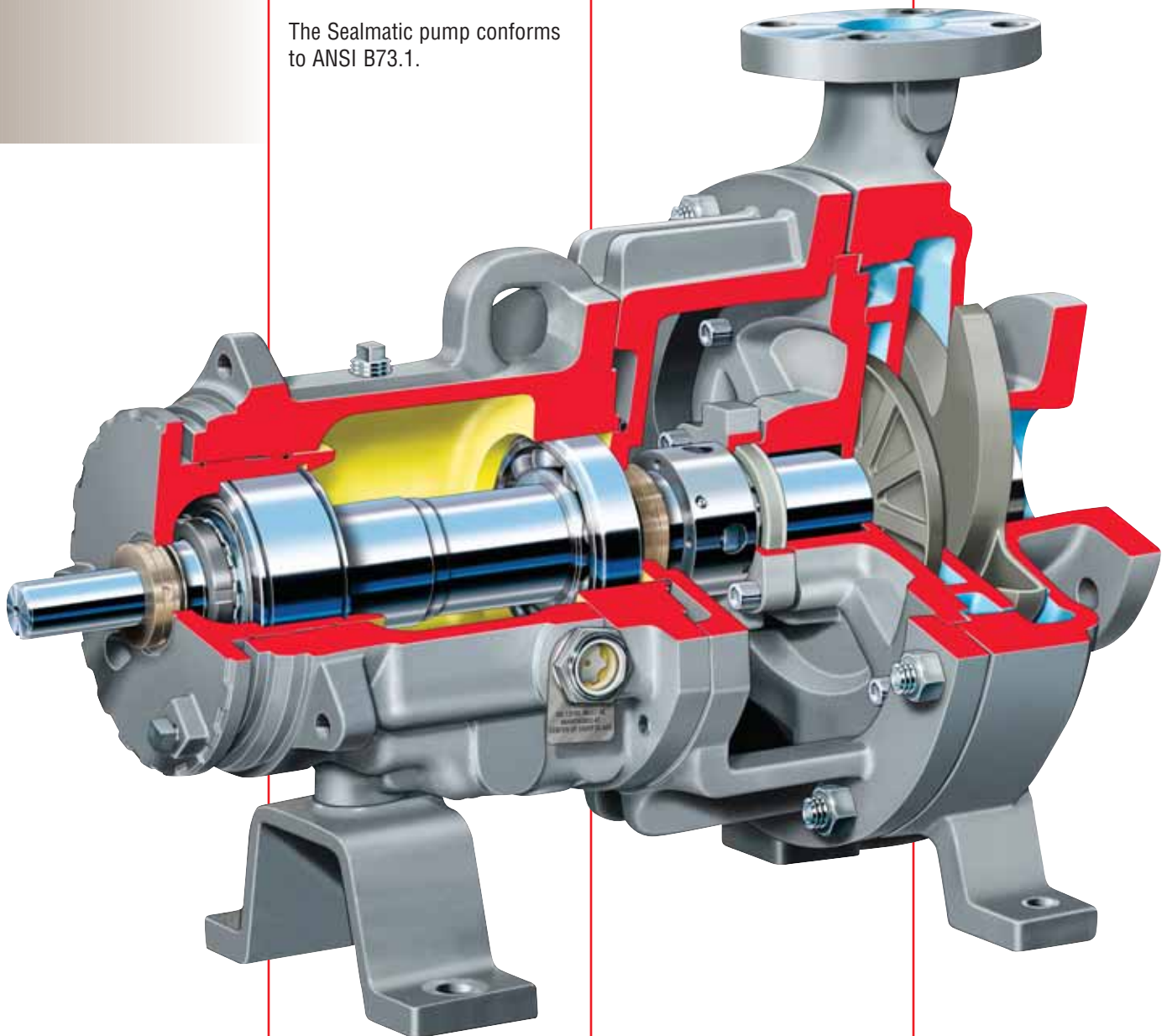

External Micrometer Impeller Adjustment accurately sets impeller clearance in 20 seconds, in the shop or the field

SealSentry™ Seal Chambers extend seal life and provide advanced self-flushing ability

Standard Reverse Vane Impeller offers repeatable pump performance throughout the life of the pump

Spinning Expeller creates centrifugal force to expel fluid from the seal chamber

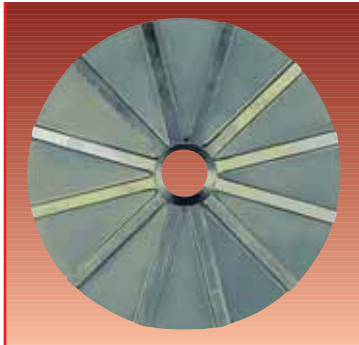

Dynamically Sealing Expeller
 evacuates liquid from the seal chamber using centrifugal force. This design is ideal for tough sealing applications.



Choice of Static Sealing Options

Flowserve provides a choice of static sealing options to keep the pump from leaking while the pump is stopped.

They include:

- Flexible graphite packing
- Dry-running end-face seal
- Stationary fluoropolymer disk seal

Seventeen Sizes

- Eleven Group 2
 2K2x1M-10A
 2K3x1.5M-10A
 2K3x2M-10A
 2K4x3M-10
 2K4x3M-10H
 2K6x4M-10
 2K6x4M-10H
 2K3x1.5M-13
 2K3x2M-13
 2K4x3M-13
 2K6x4M-13A
- Six Group 3
 3K8x6M-14A
 3K10x8M-14
 3K6x4M-16
 3K8x6M-16A
 3K10x8M-16
 3K10x8M-16H

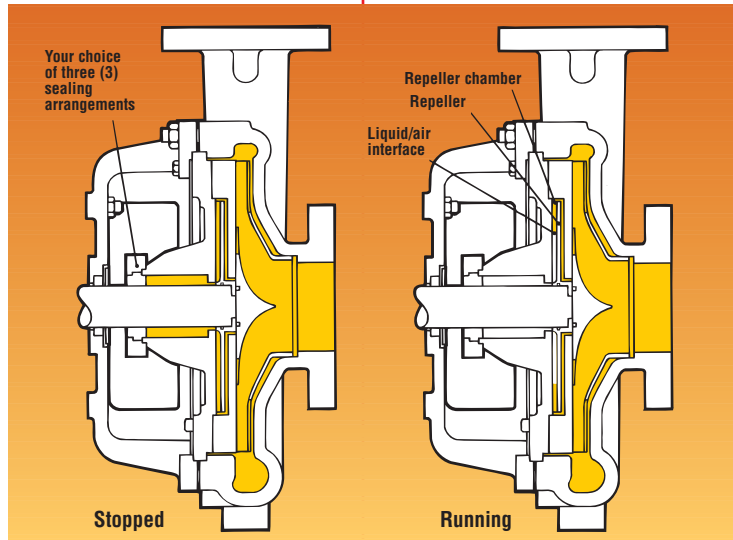
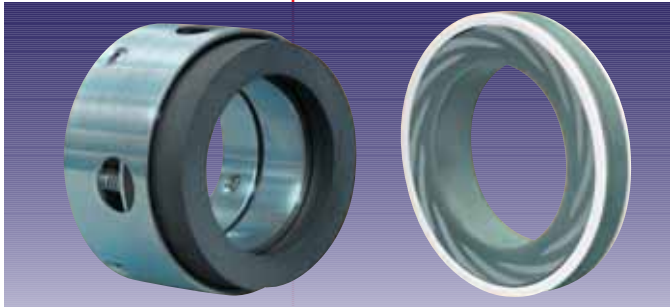

Offered in a wide range of metallurgy to meet application needs.

Additional Configurations

The Sealmatic design also is available with a recessed impeller configuration.

Benefits of Sealmatic Dynamic Sealing Technology

- Eliminates the need for conventional mechanical seals
- Eliminates need for external flush and associated product dilution
- Eliminates need for contamination control

**Mark 3
Unitized
Self-Priming
Pump**

High and Dry

The Flowserve Mark 3 Unitized Self-Priming pump is engineered to draw from liquid sources below ground level or from sources which have no positive pressure to naturally prime the pump. Conveniently located high and dry at ground level where installation is simple and maintenance is easily and more economically performed, the Mark 3 Self-Priming pump costs less to buy, install and maintain than submersible pumps.

The Mark 3 Self-Priming pump's compact design enables it to fit in tight clearance locations. It also can be mounted on a trailer for movement to various pumping locations, such as wastewater lagoon service.

Applications

- Sump service
- Tank car unloading
- Duplex pumping lift station
- Fly ash pond transfer
- Waste acid transfer
- Waste treatment lagoon service

Operating Parameters

- Flows to 320 m³/h (1400 gpm)
- Heads to 120 m (400 ft)
- Pressures to 20 bar (285 psi)
- Temperatures to 370°C (700°F)
- Static suction lift to 6 m (20 ft)

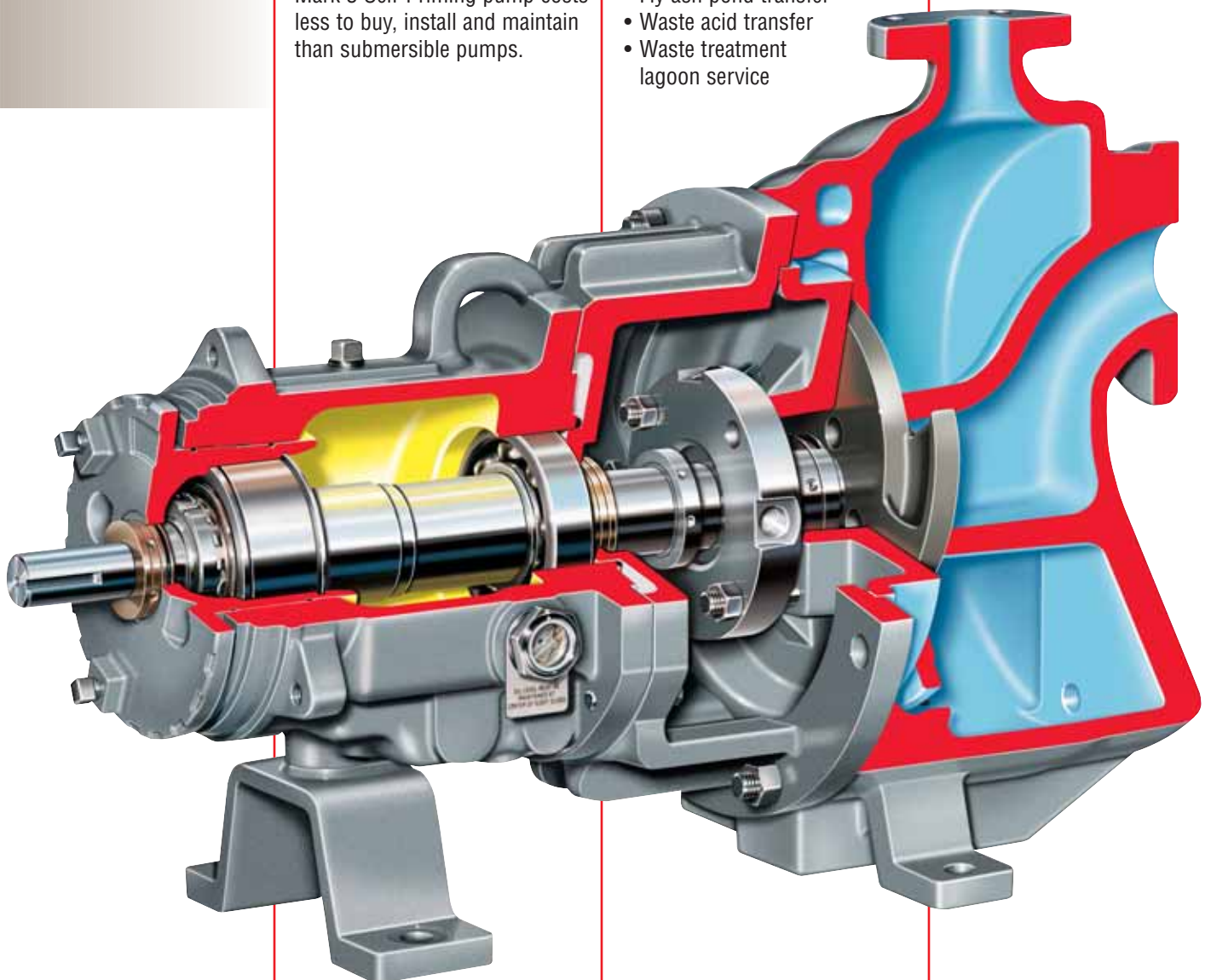

External Micrometer Impeller Adjustment accurately sets impeller clearance in 20 seconds, in the shop or the field

Standard Reverse Vane Impeller offers repeatable pump performance throughout the life of the pump

SealSentry™ Seal Chambers extend seal life and provide advanced self-flushing ability

Unitized Casing has large priming chamber, air separator and volute in one integral component. Eliminates the need for a separate priming tank



The Priming Cycle

The Mark 3 Unitized Self-Priming pump uses liquid recirculation to prime the pump. The pressure differential between the aerated liquid at the impeller and the non-aerated liquid in the priming chamber creates a vacuum that pulls liquid up the pipe. As a result, the Mark 3 Unitized Self-Priming pump is ideal for suction lift applications or pumping liquids with entrained air or gases.

Benefits of the Mark 3 Unitized Self-Priming Pump

- Eliminates internal valves
- Eliminates external priming devices or foot-valves
- Portable
- Compact
- Ease of installation
- Ease of maintenance

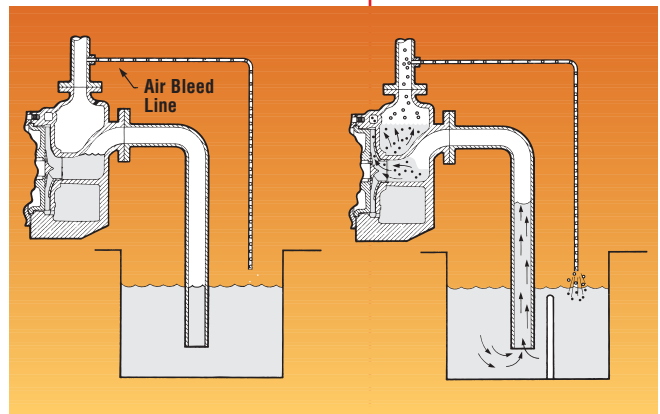

Choice of Power Ends

- Standard Mark 3A power end with double lip oil seals and top vent/breather
- ANSI 3A™ power end (see page 8) featuring Inpro VBXX bearing isolators and a lifetime warranty

Eight Sizes

- Two Group 1
 - 1J1.5x1US-6
 - 1K1.5x1.5US-82
- Six Group 2
 - 2K2x1.5US-10A
 - 2K3x2US-10
 - 2K4x3US-10H
 - 2K3x2US-13
 - 2K4x3US-13
 - 2K6x4US-13A

Offered in a wide range of metallurgy to meet application needs.

**Mark 3
Recessed
Impeller Pump**

Vortex Action

The Flowserve Mark 3 Recessed Impeller pump combines the best design features of the Mark 3 ANSI Standard pump with the vortex action of a recessed impeller. These specific purpose features along with thick wall wet-end components offer extended service life when handling solid, stringy or fibrous slurries.

Applications

- Light slurries
- Corrosive or erosive services
- Large diameter solids
- Waste streams
- Fluids with which shearing must be avoided
- Protection of solids integrity

Operating Parameters

- Flows to 455 m³/h (2000 gpm)
- Heads to 120 m (400 ft)
- Pressures to 20 bar (285 psi)
- Temperatures from -75°C (-100°F) to 370°C (700°F)

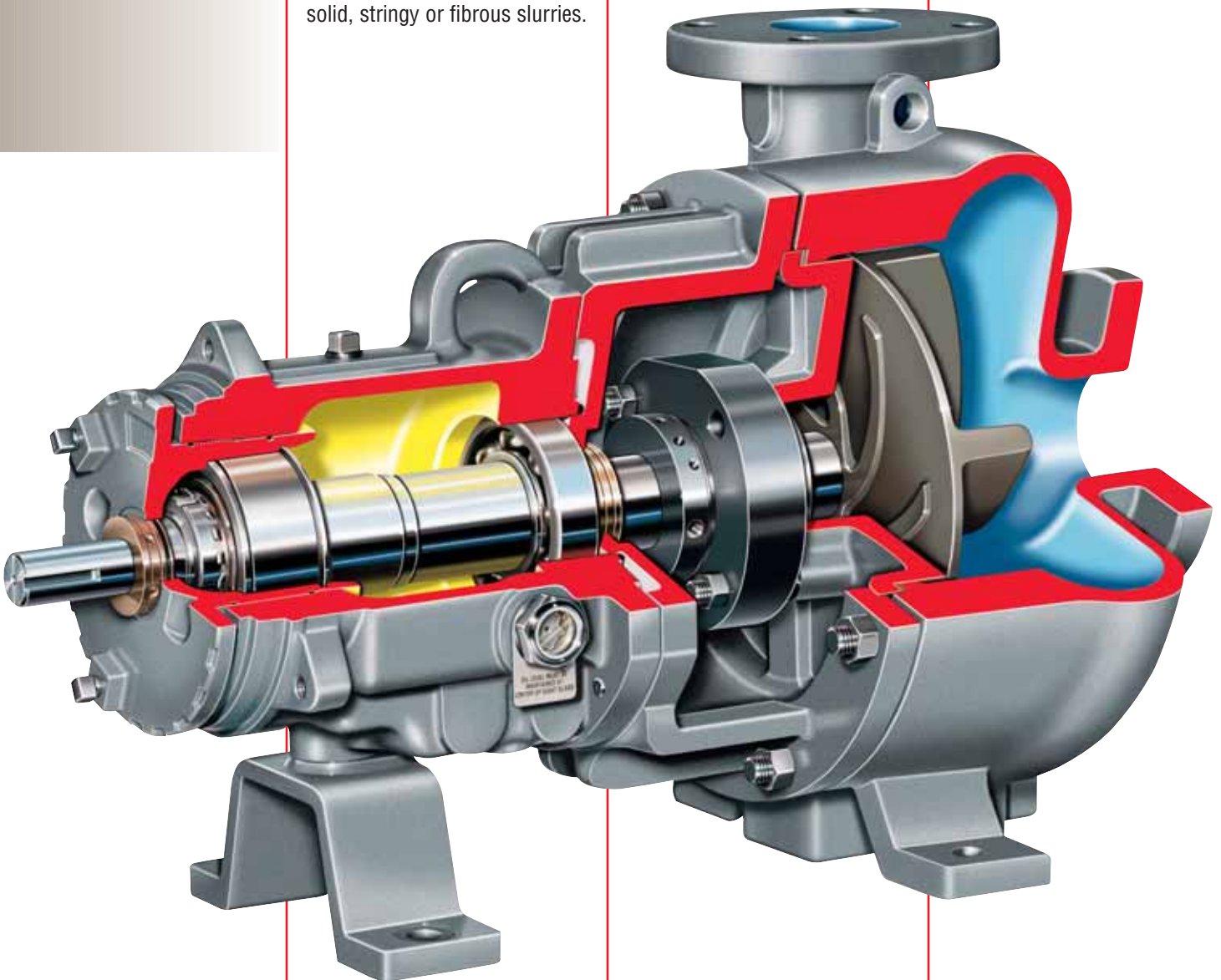

***Vortex Action** minimizes abrasive wear while maintaining solids integrity because only a fraction of the media contacts the impeller*

***Duplex Stainless Steel Construction** standard. Available in all standard Mark 3 alloys*

***Precision Cast Impeller** provided in CD4MCuN duplex stainless steel standard. All standard alloy materials available*

***SealSentry™ Seal Chambers** extend seal life and provide advanced self-flushing ability*

***Cylindrical Volute Casing With Tangential Discharge** minimizes turbulence, improving pump performance and decreasing abrasion*

Benefits of the Mark 3 Recessed Impeller Pump

- Improved solids handling
- Improved air and gas handling
- Improved ability to pass fibrous or stringy substances
- Reduced wear
- Low NPSHR

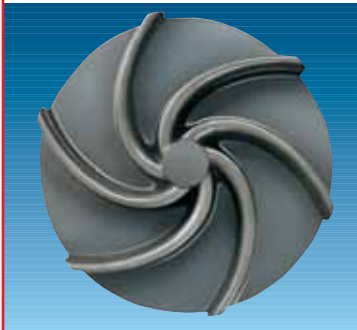

Precision Cast Open Impeller

The Mark 3 Recessed Impeller pump comes standard with an open impeller that ensures peak energy efficiency and low NPSHR. The impeller incorporates pump-out vanes that ensure low, positive seal chamber pressure and expel solids from critical seal areas. Mechanical seal or packing life is maximized.

Cylindrical Volute Casing

minimizes radial loads on the impeller. The result is longer seal life as well as maximized radial bearing life.

Vortex Pumping Action

The vortex created by the spinning impeller does the pumping with less than 20% of media contacting the impeller. Abrasive wear is minimized and solids integrity maintained.

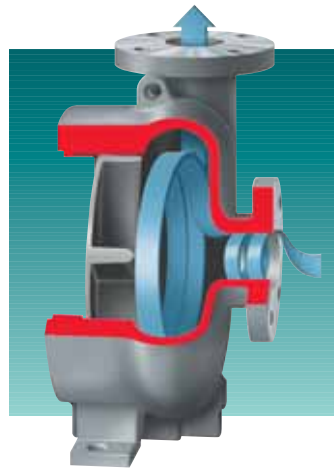

Choice of Power Ends

- Standard Mark 3A power end with double lip oil seals and top vent/breather
- ANSI 3A™ power end (see page 8) featuring Inpro VBXX bearing isolators and up to a lifetime warranty

Five Sizes

- One Group 1
1J2x2R-6
1K1.5x1.5US-82
- Four Group 2
2K2x2R-10
2K3x3R-10
2K4x3R-13
2K6x4R-13

Offered in a wide range of metallurgy to meet application needs.

Additional Configurations

The Mark 3 Recessed Impeller pump can be specified with the Sealmatic dynamically sealing expeller and as self-priming with priming tank option.



**Mark 3
In-Line
Chemical
Process Pump**

Without Equal
Designed to exceed ANSI B73.2 criteria, the Mark 3 In-Line process pump offers improved pump reliability and extended pump life. The space-saving Mark 3 In-Line has broad application in chemical and hydrocarbon processing as

well as in general industry for services, including:

- Chemical transfer
- Heat transfer
- Liquid gases
- Storage
- Water
- Washdown and cleaning
- Condensate return
- Light slurries

Operating Parameters

- Flows to 370 m³/h (1630 gpm)
- Heads to 230 m (760 ft)
- Pressures to 24 bar (350 psi)
- Temperatures to 370°C (700°F)
- Motor sizes to 110 kW (150 hp)

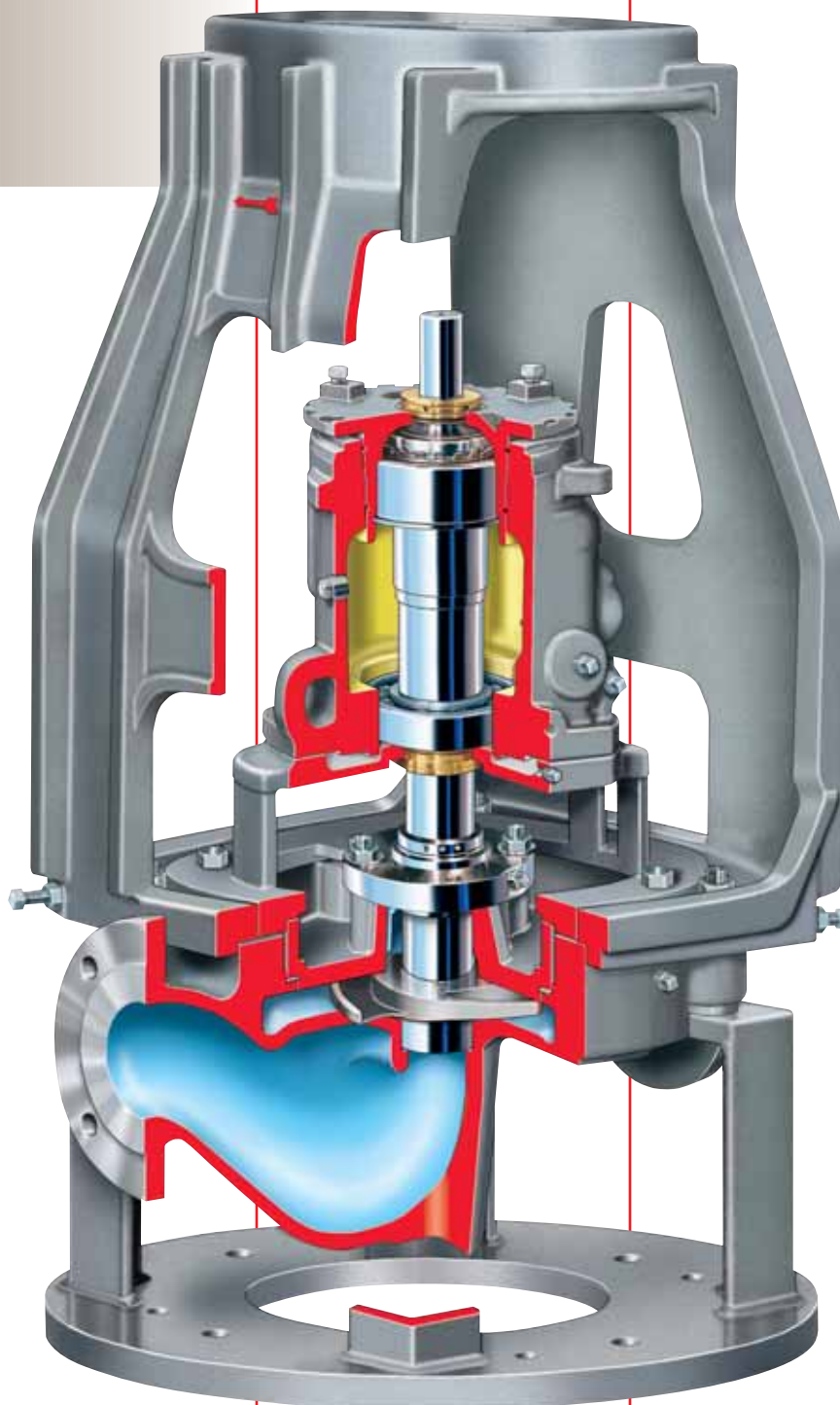

Please see Bulletin PS-10-15 for more complete product information.

**Flowserve
PolyChem™
and GRP
Non-metallic
Pumps**

**PolyChem S-Series
Fluoropolymer Lined
Chemical
Process Pump**

The non-metallic PolyChem S-Series chemical process pump conforms to ANSI B73.1, ISO 2858 and JIS drilling standards to meet global demands. Its PFA-lined wet end offers outstanding corrosion and temperature resistance.

Operating Parameters

- Flows to 420 m³/h (1860 gpm)
- Heads to 145 m (480 ft)
- Pressures to 17 bar (250 psi)
- Temperatures from -30°C (-20°F) to 150°C (300°F)

Please see Bulletin PS-10-17 for more complete product information.

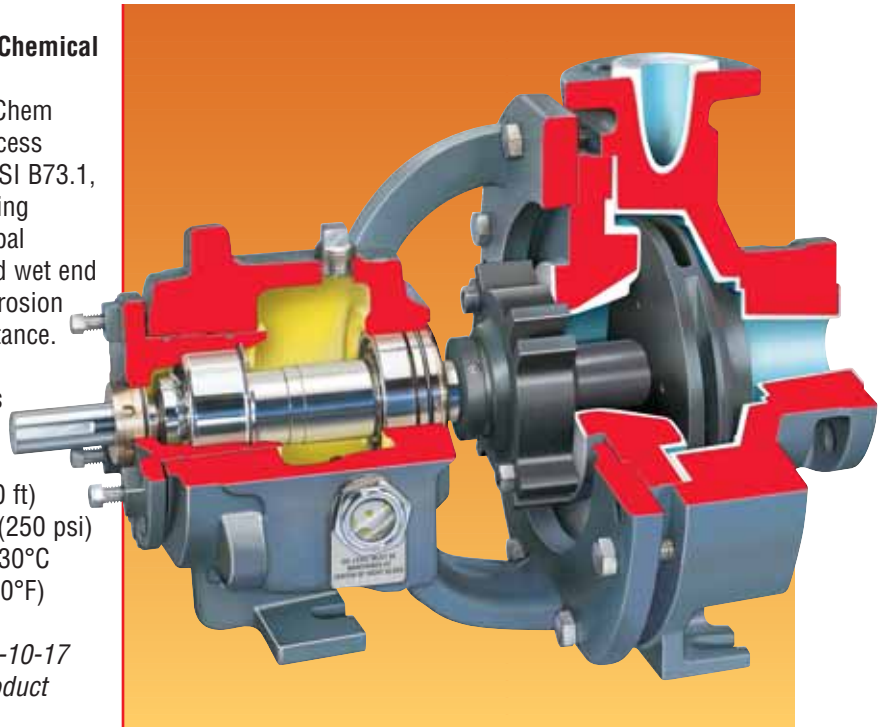

**GRP Engineered
Polymer Composite
Chemical Process Pump**

The GRP glass reinforced vinyl ester chemical process pump conforms to ANSI B73.5. With corrosion resistance superior to more expensive, high alloy metals and costs closer to that of ductile iron, the GRP pump has proven to be the low-cost, long-term solution in corrosive applications.

Please see Bulletin PS-10-17 for more complete product information.

Operating Parameters

- Flows to 2500 m³/h (11 000 gpm)
- Heads to 150 m (500 ft)
- Pressures to 17 bar (250 psi)
- Temperatures to 120°C (250°F)

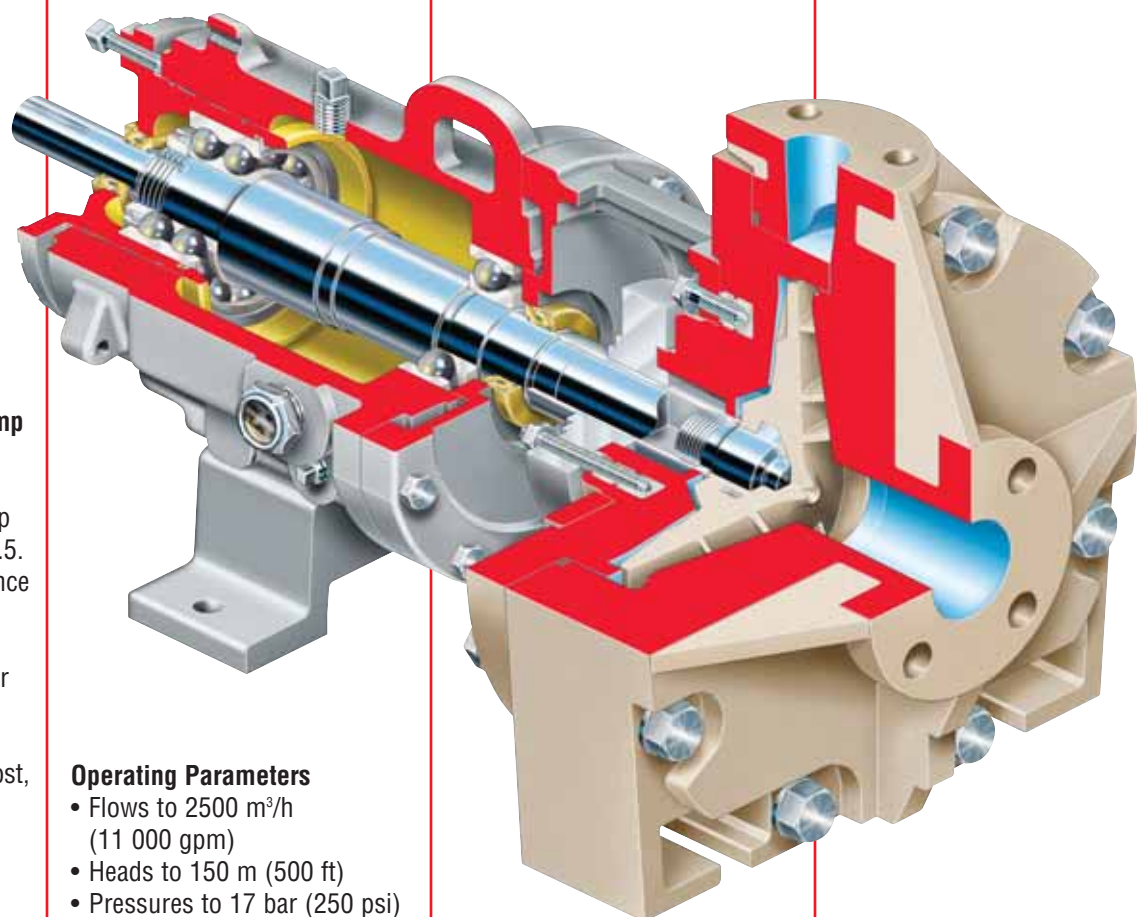

**Flowserve
CPXS, PolyChem
and Guardian
Magnetic Drive
Pumps**

CPXS ISO Magnetic Drive Pump

The CPXS magnetic drive process pump conforms to ISO 2858 dimensional and ISO 5199 design criteria. It is CE marked and compliant with applicable European directives, such as ATEX.

Operating Parameters

- Flows to 420 m³/h (1850 gpm)
- Heads to 160 m (525 ft)
- Pressures to 25 bar (365 psi)
- Temperatures from -40°C (-40°F) to 370°C (700°F)

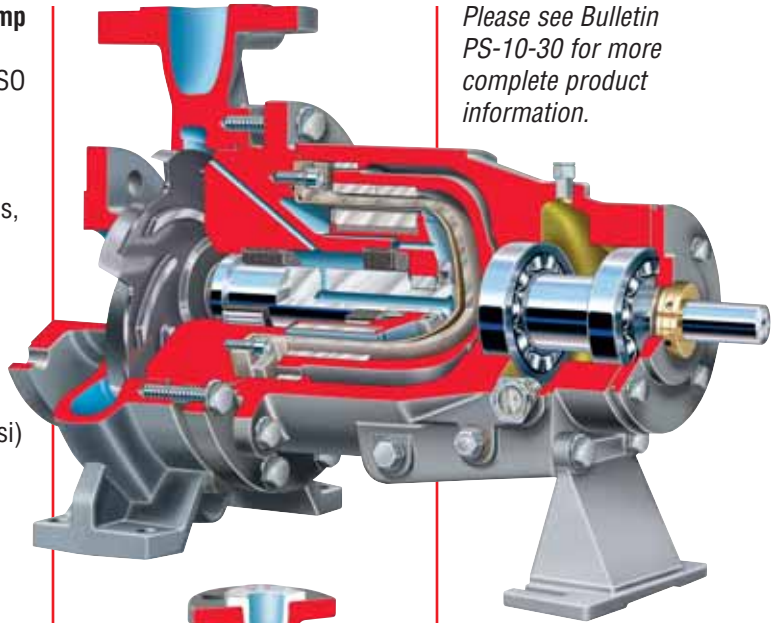

Please see Bulletin PS-10-30 for more complete product information.

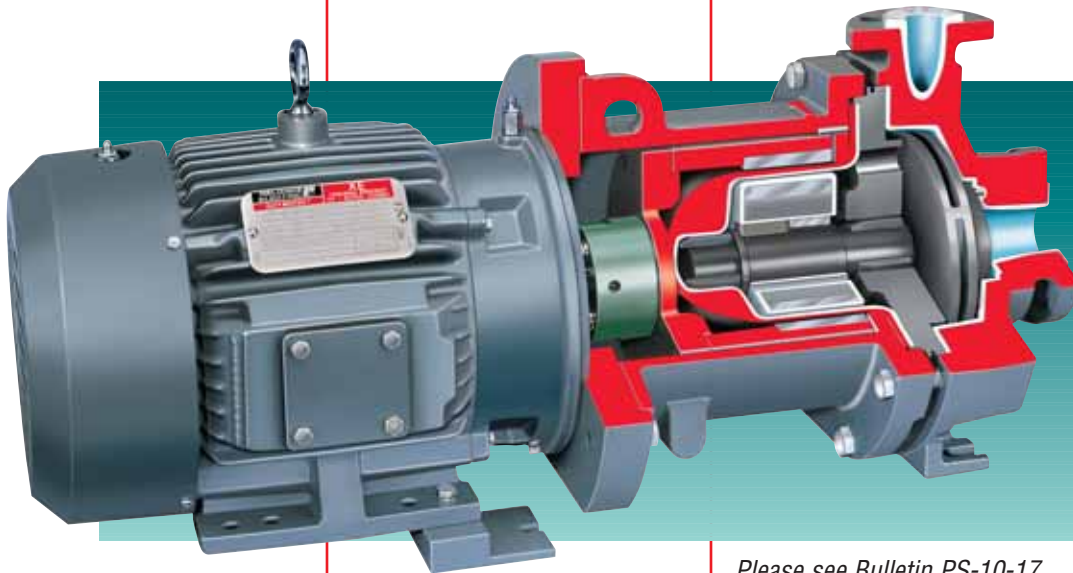

**PolyChem M-Series
PFA-Lined Magnetic
Drive Pump**

The PolyChem M-Series fluoropolymer lined, magnetic drive pump meets ANSI B73.1, ISO 2858 and JIS drilling standards.

Operating Parameters

- Flows to 135 m³/h (600 gpm)
- Heads to 145 m (480 ft)
- Pressures to 17 bar (250 psi)
- Temperatures to 150°C (300°F)

Please see Bulletin PS-10-17 for more complete product information.

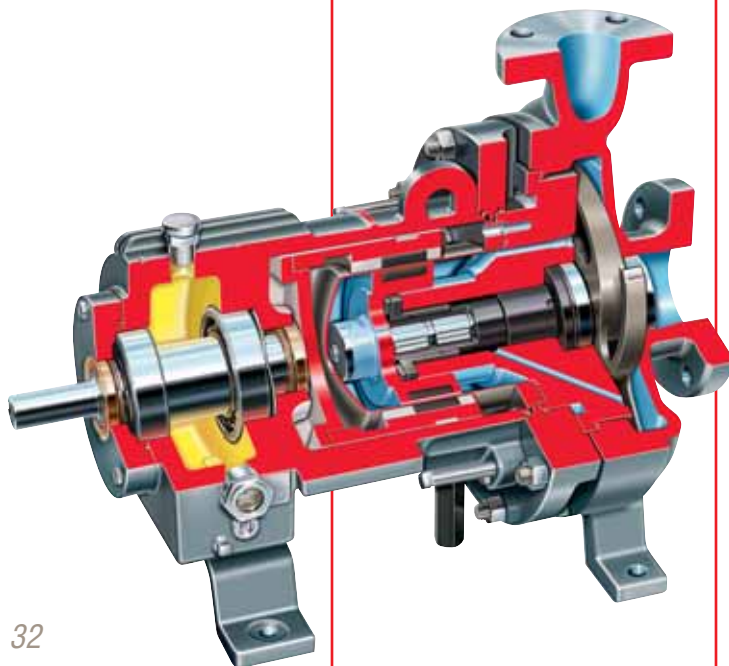

**Guardian G & H Series
Magnetic Drive Pumps**

The Guardian magnetic drive pumps meet ANSI B73.1 dimensional standards and are available in 18 sizes. Offered in a wide range of corrosion-resistant materials, the Guardian magnetic drive pump is ideal for high temperature, leak-free applications.

Operating Parameters

- Flows to 375 m³/h (1650 gpm)
- Heads to 215 m (700 ft)
- Pressures to 24 bar (350 psi)
- Temperatures to 288°C (550°F)

Please see Bulletin P-20-500 for more complete product information.

Durco KW941 Pump Power Monitor

The KW941 Pump Power Monitor monitors and displays actual power to the pump, offering simultaneous protection from underload and overload operating conditions.

The KW941 helps to eliminate costly downtime and expensive pump repairs caused by:

- Dry running
- Pump overloads
- Cavitation
- Blocked lines
- Closed suction or discharge valves
- Excessive wear or rubbing

Broad Application Range

- Works on all pumps having steady (non-pulsating) loads: centrifugal; gear; turbine; ANSI; API; ISO; paper stock; sealed; mag drive; canned motor; self-priming
- One model for up to 600 hp (450 kW). Premium features for reliable protection
- Push buttons display horsepower or kilowatts; automatic conversion when switching displays
- Adjustable low power and high power set points protect pump from underload and overload operation. Alarms can be tripped or pumps shut down before damage occurs
- Adjustable trip delay timers filter out nuisance trips caused by temporary power fluctuations
- Adjustable start-up delay timer is particularly useful in self-priming applications
- 4 to 20 milliamp analog output facilitates remote displays, operator interface and output to PLC or DCS
- Two form C relay outputs for low and high power trips. Outputs can be used to shut down pump or trip alarms
- Automatic, manual and remote reset options for versatile operation

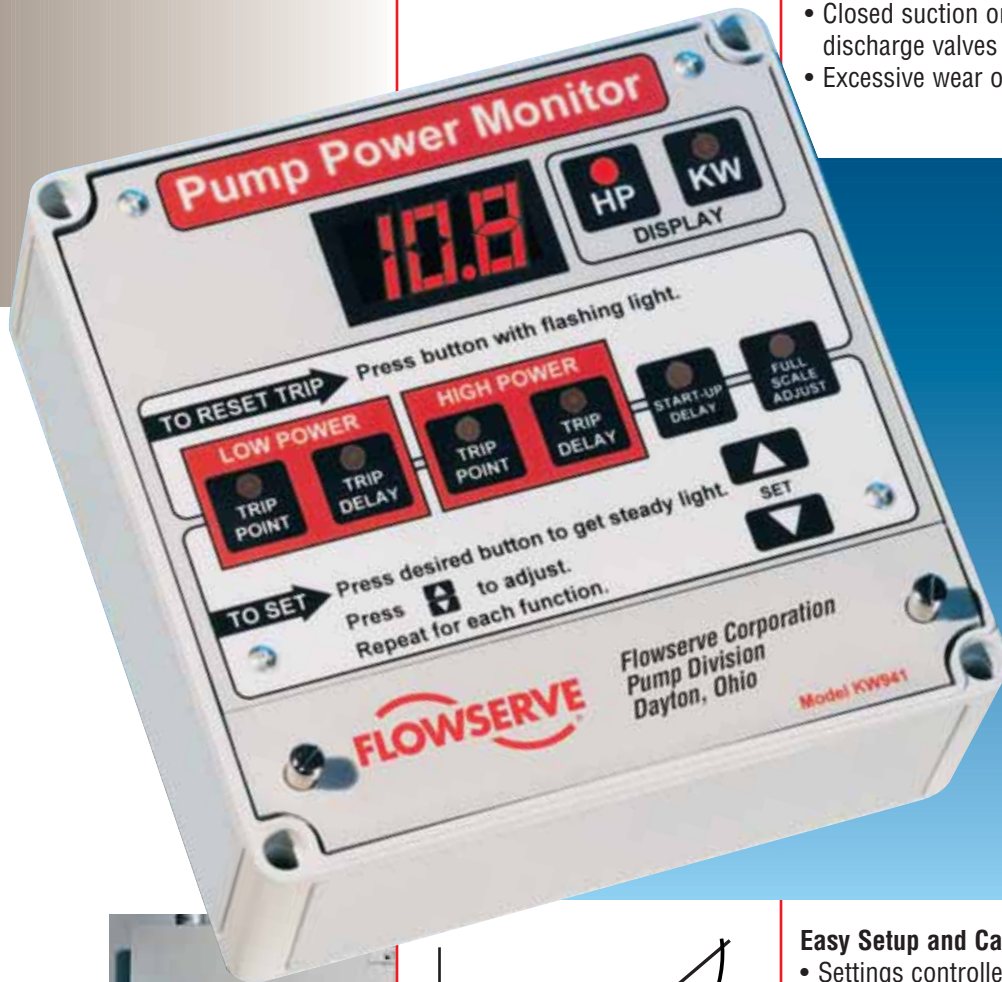

The KW941 Power Monitor is easy to install on new or existing pump installations. All connections and controls are located at motor starter electrical enclosure as shown. Costly instrumentation wiring to the pump is eliminated

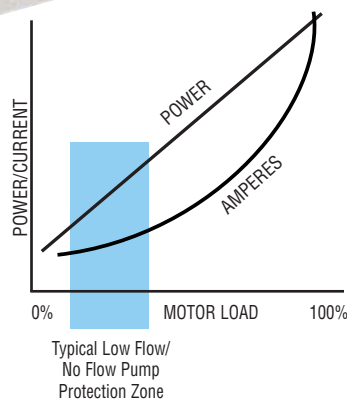

By Sensing Power and not just amperes, linear measurements are provided with the sensitivity to detect improper operation while eliminating unwanted nuisance trips

Easy Setup and Calibration

- Settings controlled from front panel push buttons; no internal adjustments, dip switches or potentiometers
- Large digital display for easy viewing and accurate settings
- One step calibration can be performed without operating pump. No need to run pump at off-operating conditions to calibrate power monitor
- Settings can be viewed or adjusted during normal pump operation

**Flowserve
CPX and FRBH
Process Pumps**

**CPX Family of ISO
Chemical Process Pumps**

The CPX family of ISO chemical process pumps offers a wide range of configurations including mechanically sealed, magnetic drive, self-priming, close-coupled and vertical pumps. Parts interchangeability among the configurations is a key benefit of the CPX family, translating into inventory and maintenance costs savings.

Operating Parameters

- Flows to 370 m³/h (1630 gpm)
- Heads to 230 m (760 ft)
- Pressures to 24 bar (350 psi)
- Temperatures to 370°C (700°F)
- Motor sizes to 110 kW (150 hp)

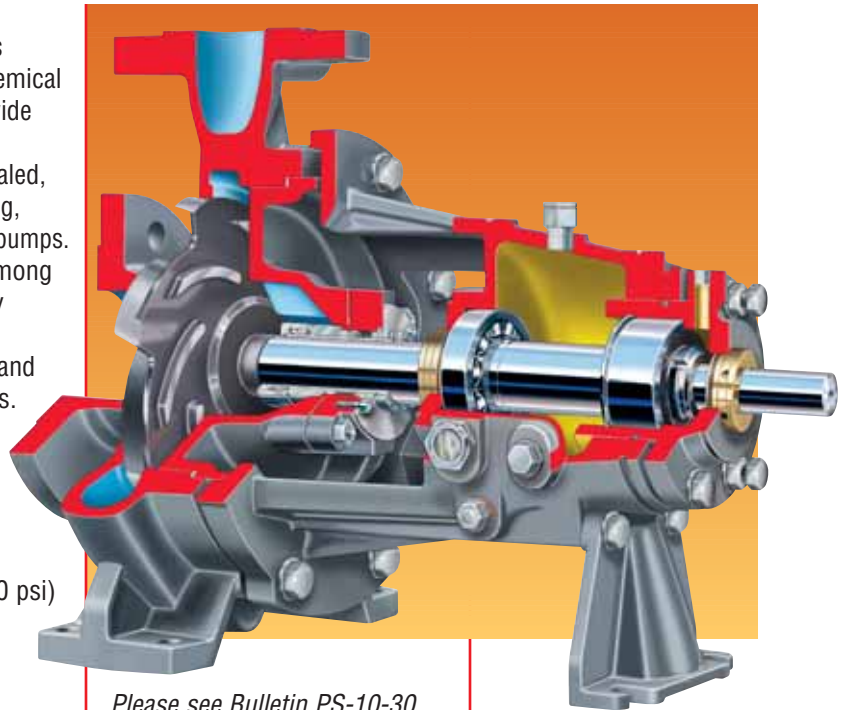

Please see Bulletin PS-10-30 for more complete product information.

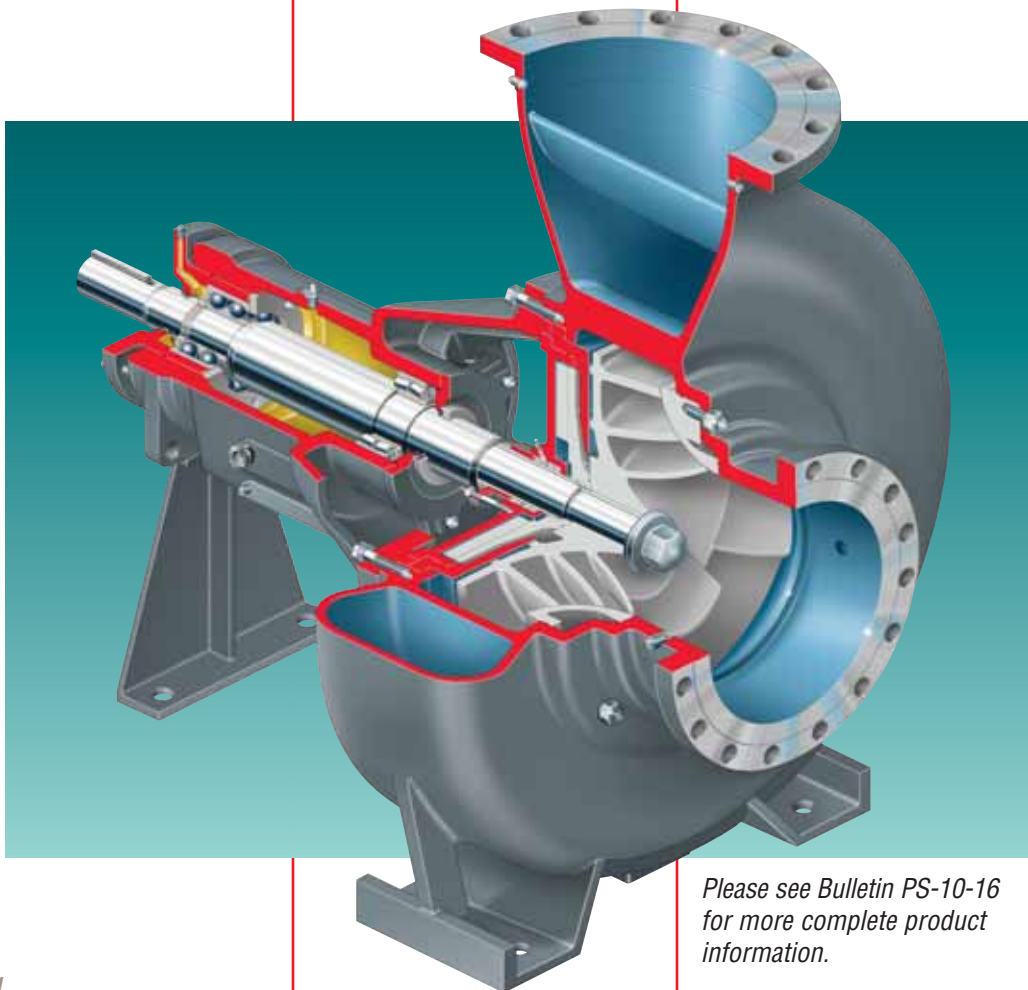

**FRBH Heavy-Duty
Paper Stock and
Process Pump**

The FRBH is one of the world's most efficient and reliable pumps – one that will perform effectively not only at the best efficiency point but across a broad operating range. The high efficiency and rugged construction of the FRBH translate into reduced operating costs.

Operating Parameters

- Flows to 6800 m³/h (30 000 gpm)
- Heads to 100 m (325 ft)
- Pressures to 14 bar (200 psi)
- Temperatures to 150°C (300°F)

Please see Bulletin PS-10-16 for more complete product information.

Global Engineered Services and Support

- Total Cost Reduction*
- Asset Management*
- Product Life Cycle*
- Performance Re-rates*
- Site Diagnostics*
- Repair Services*
- Energy Management*
- Spare Parts*
- Maintenance Contracts*
- Materials Upgrades*
- Turnkey Services*
- Field Repairs*
- Installation*
- Project Supervision*
- Commissioning*
- Equipment Upgrades*
- Condition Monitoring*
- Systems Analysis*
- Field Machining*

Service Dedication

Flowserve Engineered Services is focused on providing customers with uncompromising service and support, where and when needed. Dedicated to delivering the highest quality support, Engineered Services integrates its extensive pump and materials engineering knowledge with creative service solutions. Engineered Services fully understands the business challenges facing customers and is prepared to manage solutions to succeed as a team.

A worldwide network of service and repair centers staffed by highly skilled engineers and technicians is available around the clock, seven days a week to respond to customer queries, to evaluate and troubleshoot problems and to provide reliable solutions.



Strength of Experience, Commitment to Excellence

Flowserve has long served industries requiring superior equipment performance and service life.

- Oil and gas production
- Hydrocarbon processing
- Chemical processing
- Water resources
- Power generation
- Nuclear
- Mining and mineral processing
- Pulp and paper
- General industry

Engineered Services is dedicated to maximizing equipment performance and providing reliability-centered maintenance programs for pumps and related equipment, regardless of manufacturer. Using the FlowStar™ asset management software, Engineered Services tracks performance and supports improvement programs using a service life cycle cost business approach. The results are improved reliability and increased profitability.

Business Partner

Flowserve partners with customers to respond to the dynamic business conditions that affect them. Flowserve will work with customers to drive efficiency, maximize throughput and control process quality. Whether user needs involve on-site technical assistance or broader project planning with full turnkey responsibility, Flowserve Engineered Services will deliver professional, reliable results.



**Flowserve... Supporting Our Customers
With The World's Leading
Pump Brands**



USA and Canada

Flowserve Corporation
Pump Division
5215 North O'Connor Blvd.
Suite 2300
Irving, Texas 75039-5421 USA
Telephone: 1 972 443 6500
Telefax: 1 972 443 6800

Europe, Middle East, Africa

Worthington S.P.A.
Flowserve Corporation
Via Rossini 90/92
20033 Desio (Milan), Italy
Telephone: 39 0362 6121
Telefax: 39 0362 303396



Pump Division

Your local Flowserve representative:

**To find your local Flowserve representative
please use the Sales Support Locator System
found at www.flowserve.com**

Or call toll free: 1 800 728 PUMP

Latin America and Caribbean

Flowserve Corporation
Pump Division
6840 Wynnwood Lane
Houston, Texas 77008 USA
Telephone: 1 713 803 4434
Telefax: 1 713 803 4497

Asia Pacific

Flowserve Pte. Ltd.
Pump Division
200 Pandan Loop #06-03/04
Pantech 21
Singapore 128388
Telephone: 65 6775 3003
Telefax: 65 6779 4607

Printed in U.S.A.
July 2004

© Flowserve Corporation