

8.5 Sectional drawings – LRV double entry impeller, grease lubricated thrust bearing, component mechanical seal, SiC bearing

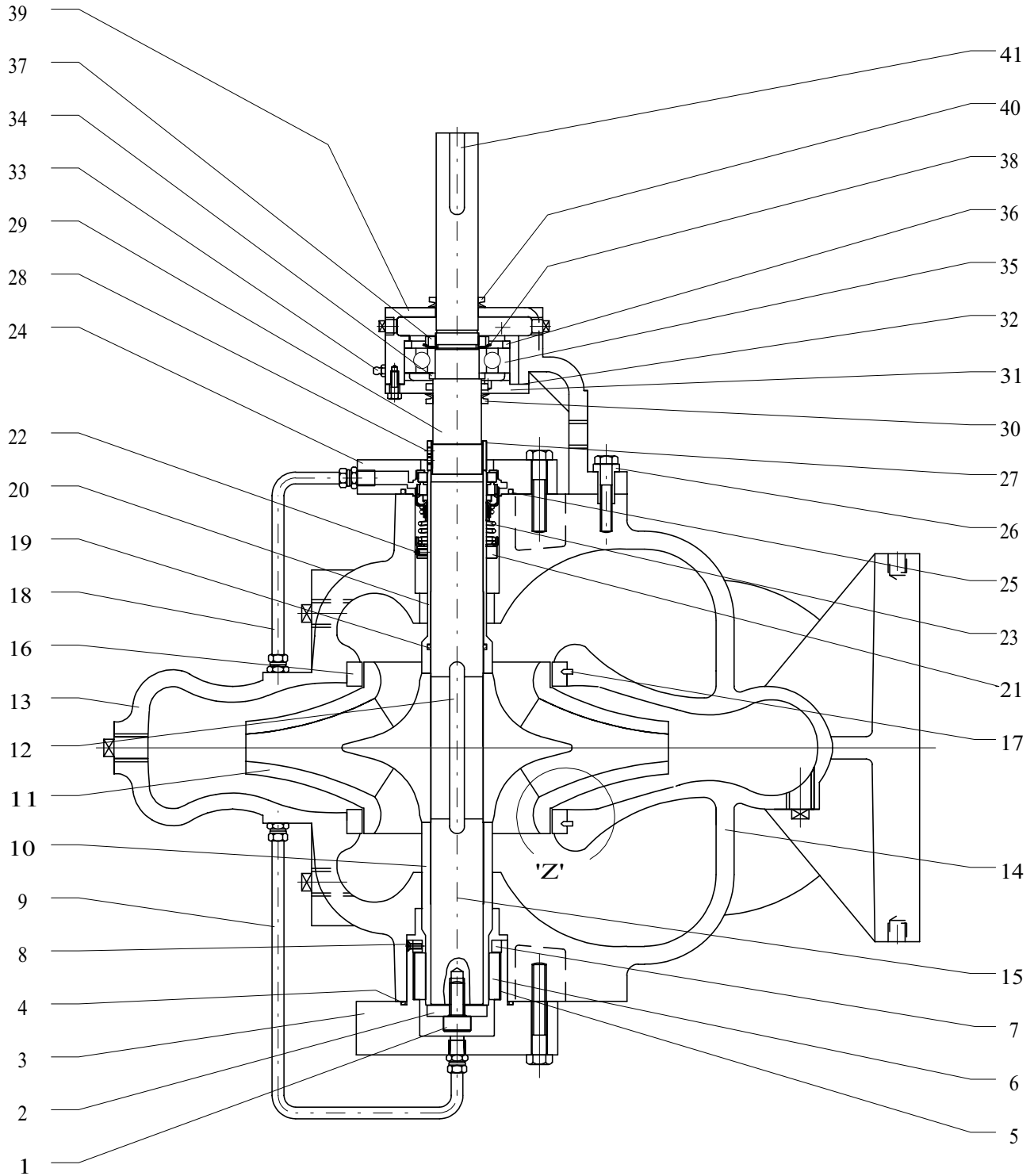

Taken from A336/033

8.5.1 Parts list – LRV

Ref. no.	Description
1	Socket head capscrew
2	Sleeve end cap
3	Bottom bearing housing
4	O-ring, bottom bearing housing
5	Tolerance ring
6	Bearing bush - SiC
7	Retaining ring, bearing bush
8	Socket head screw
9	Bearing flush pipe assembly
10	Shaft sleeve, bottom
11	Impeller
12	Key, impeller
13	Casing - upper half
14	Casing - lower half
15	Gasket - horizontal split
16	Casing wear ring
17	Anti-rotation screw (b)
18	Seal pipe assembly
19	O-ring - top sleeve
20	Shaft sleeve, top
21	Abutment ring - mech. seal (a)
22	Socket head screw for 21 (a)
23	Mechanical seal
24	Mechanical seal cover
25	O-ring, mech. seal cover
26	Dowel bushing
27	Shaft nut
28	Socket head screw for 27 & 43
29	Shaft
30	V-ring, inboard
31	Bearing cover, drive end
32	Gasket, bearing cover
33	Grease nipple
34	Thrust bearing spacer (c)
35	Ball bearing, thrust
36	Shim (d)
37	Bearing locknut
38	Lockwasher, bearing locknut
39	Bearing bracket
40	V-ring, outboard
41	Key, coupling

- a) When fitted, depends on type of mechanical seal.
- b) True position is on casing bottom half gasket face.
- c) When fitted, depends on pump size.
- d) Not fitted on 10LR17 and 10LR18. The shim is inboard of the bearing on the 6LR18, 8LR20, 10LR14 and 10LR16.

8.5.2 Options - LRV

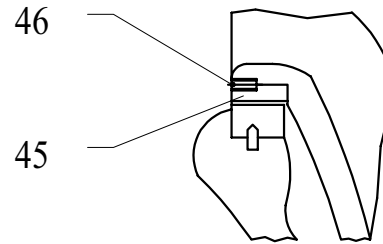

View on 'Z' impeller ring

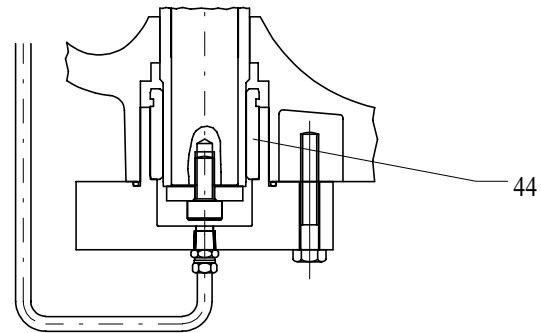

Cutless rubber bearing bush

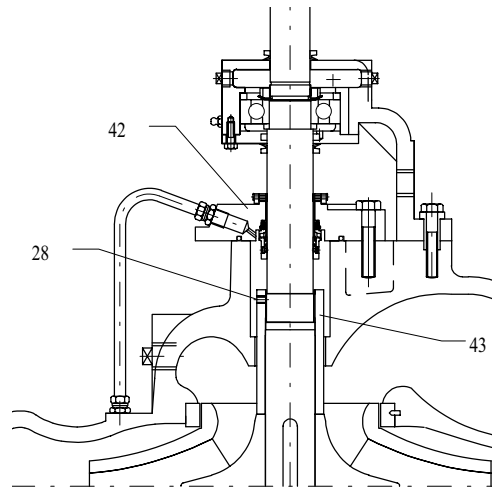

Cartridge mechanical seal

8.5.3 Options parts list - LRV

Ref. no.	Description
42	Cartridge seal assembly
43	Impeller nut
44	Bearing bush, Cutless rubber
45	Impeller ring
46	Socket head screw